



Spare Parts Catalog

16 S 1825 TO

Material number: 1341.031.022
1341.002.056



Pos.	Information	Amendment number
001	Use case -----	
002	Customer UralAZ Joint Stock Co.	
003	City Miass	
004	DUNS	
005	Vehicle / Apparatus -----	
006	Sales Name	
007	Manufacturer UralAZ Joint Stock Co.	
008	Engineering Name	
009	Product Use TRUCK	
010	Vehicle/Hardware Type ROAD TRACTOR	
011	SOP	
012	Engine	
013	Sales Designation 6501.10	
014	Manufacturer Yamz	
015	Eng.Displ. cm3	
016	Cylinder	
017	Nom. power 266 kW	
018	RPM at nom. power 1900 1/min	
019	Nom. torque 1668 Nm	
020	RPM at nom. torque 1200 1/min	
021	Classification use case -----	
022	DESIGNATION, CLUTCH MFZ430	
023	MANUFACTURER, CLUTCH ZF-SACHS	
024	TOTAL NUMBER OF WHEELS 6	
025	NUMBER OF DRIVING WHEELS 4	
026	DYNAMIC TYRE RADIUS 550 mm	
027	REAR AXLE RATIO 4.8	
031	PERMISS.GROSS VEHICLE WEIGHT 33.5 t	
033	APPROVAL NOTE 1 FIRST FITTING CHECK CARR.OUT	
034	Product description -----	
052	AUSFUEHRUNG PTO J32 N 221/10 C	
053	LAGE PTO J32 TOP	



Pos.	Information	Amendment number
054	SCHALTUNGSART PTO J32 PNEUMATIC INTEGRATED	
055	ZAEHNEZAHL PTO ANTR.RAD Z1 J32 44	
056	ZAEHNEZAHL PTO ABTR.RAD Z3 J32 23	
057	OUTPUT SPEED PTO(X N-MOTOR)J32 1.75	
064	OIL CAPACITY, GEARBOX 12.000 dm3	
066	OIL GRADE PERMISSIBLE ACC. TO TE-ML02	
067	OIL CLASS FIRST FILLING H	
068	CODING OUTER CONSERVATION KA1	
069	SCOPE OUTER CONSERVATION T	
070	CODING INNER CONSERVATION KI1	
071	CONSERVATION SPECIFICATION ZFN 916	
072	COLOR JET BLACK	
073	COLOUR CLASSIFICATION ACC. TO RAL 9005	
074	PAINTING, ZF STANDARD 915 W	
075	Documents -----	
076	16-SPEED GEARB. Drawing 1341.602.003	



Graphics	Pos.	Material number	Name	VKF	Amend. no.	Amend. start	Prod. no.	Material feature / tech. info.	ID
068.a1.01-1	910	1341.002.056	16 S 1820 TO	1		00.00.0000		SG-KK*LL*ANGEFL*DW-WL H-H *N221/10C MONT	1
	916	6091.004.073	N 221/10 C	1		00.00.0000		Z44/23*ABTR.OBEN *F.ERZ.KOMB	1
068.64.02-1	130	6091.101.803	PLATE	1		00.00.0000		N221/10B+C * NM AS/10B+C *NL10 B+C	3
068.64.02-1	900	6091.101.022	HOUSING	1		00.00.0000		N221/10B+C *ABTR.OBEN+UNTEN	3
068.65.15-1	910	6091.102.007	INPUT	1		00.00.0000		N221/10B+C SOLO+LP+IT*Z44 *ABTR.OBEN+UNTEN	3
068.67.02-1	930	6091.104.008	OUTPUT	1		00.00.0000		N221/10C*SOLO+LP+IT*Z23 *ABTR.OBEN	3
068.69.01-1	184	6091.107.400	CONNECTING PARTS	1		00.00.0000		NA-ANZ SCHL*ABTR.OBEN	3
068.69.01-1	944	6091.107.001	GEAR SHIFT SYSTEM	1		00.00.0000		N221/10B+C SOLO+LP+IT *ABTR.OBEN	3
	918	6091.190.005	ACCESSORIES	1		00.00.0000		N 221/10	3
068.64.51-1	910	6091.101.804	HOUSING	1		00.00.0000		N221/10B+C*ABTR.OBEN +UNTEN*LOSE LIEF+ANBAU	3

VKF Incidence factor

ID Identification (output code)

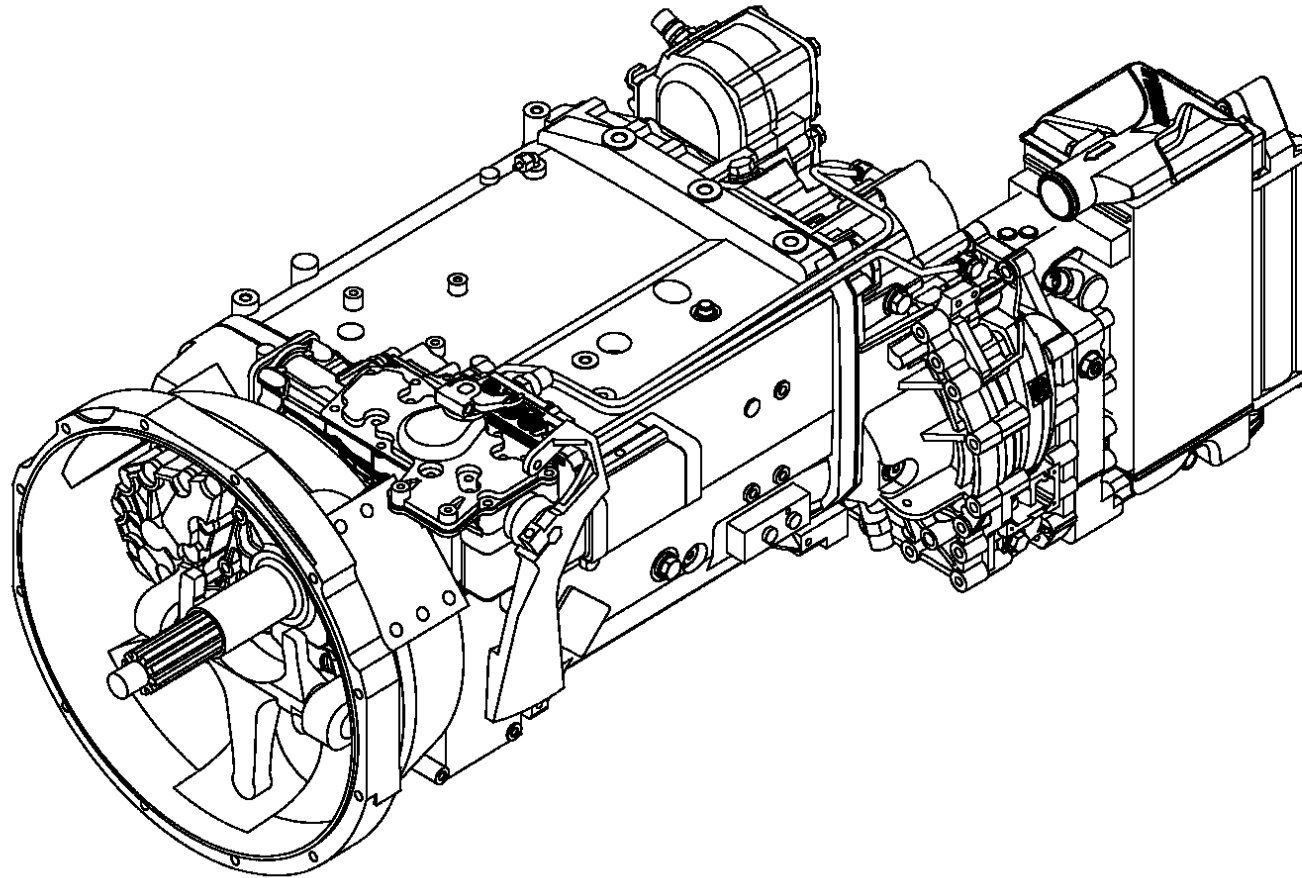



Pos.	Material number	Name	VKF	Amend. no.	Amend. start	Prod. no.	Material feature / tech. info.	OTK	External material no.	ID	Weight	SP
130	6091.101.803	PLATE	1		00.00.0000		N221/10B+C * NM AS/10B+C * NL10 B+C			3	0,000	
184	6091.107.400	CONNECTING PARTS	1		00.00.0000		NA-ANZ SCHL*ABTR.OBEN			3	0,000	
900	6091.101.022	HOUSING	1		00.00.0000		N221/10B+C *ABTR.OBEN+ UNTEN			3	0,000	
910	6091.102.007	INPUT	1		00.00.0000		N221/10B+C SOLO+LP+IT* Z44 *ABTR.OBEN+UNTEN			3	0,000	
930	6091.104.008	OUTPUT	1		00.00.0000		N221/10C*SOLO+LP+IT*Z23 * ABTR.OBEN			3	0,000	
944	6091.107.001	GEAR SHIFT SYSTEM	1		00.00.0000		N221/10B+C SOLO+LP+IT * ABTR.OBEN			3	0,000	

VKF Incidence factor

OTK Optional technical kit

ID Identification (output code)

SP Supplier plant

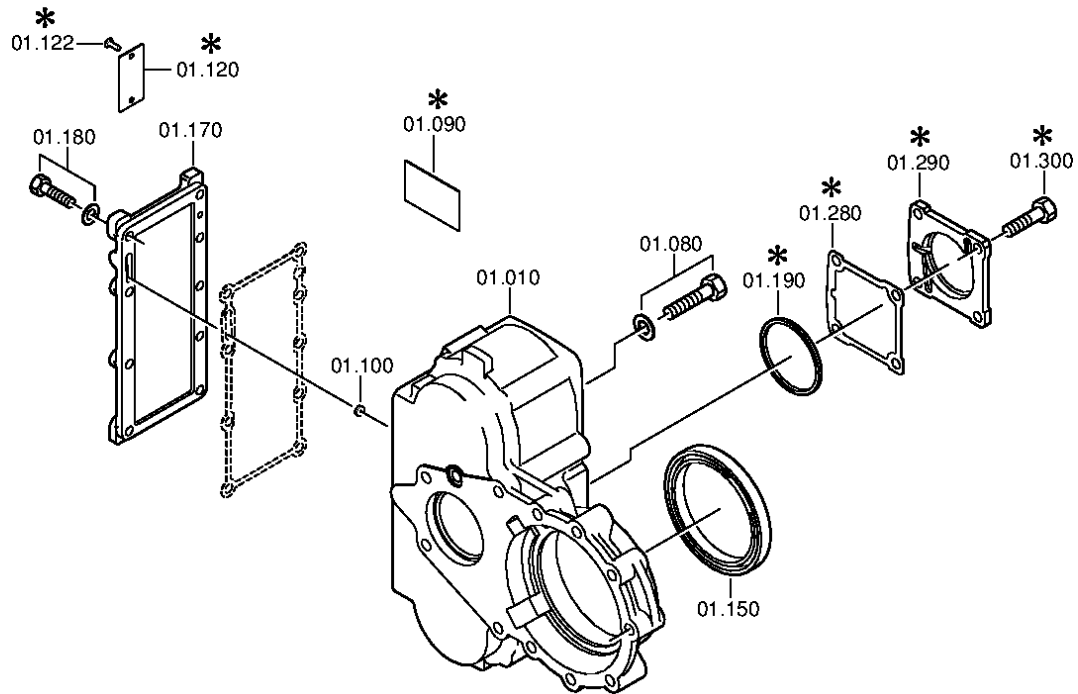



Pos.	Material number	Name	VKF	Amend. no.	Amend. start	Prod. no.	Material feature / tech. info.	OTK	External material no.	ID	Weight	SP
10	6091.301.035	HOUSING	1		00.00.0000		N221/10			5	0,000	
80	---	HEXAGON BOLT	2		00.00.0000		SCHUTZHUELSE M12X40			3	0,000	
---	0636.100.822	HEXAGON BOLT	2	Z0000795 8512	01.01.2012	01.01.2012	M12X40			5	0,000	
---	0630.100.284	WASHER	2	Z0000715 8210	01.01.2012	01.01.2012				5	0,000	
90	1296.313.166	PLATE	1		00.00.0000					5	0,000	
100	0730.361.077	ORIFICE	1		00.00.0000				MX252720	5	1	
120	0730.365.160	TYPE PLATE	1		00.00.0000		PTO			5	0,000	
122	0731.300.027	BLIND RIVET	2	Z0000790 4810	01.01.2012	01.01.2012				5	0,000	
150	---	SHAFT SEAL	1		00.00.0000		105X130X12			3	0,000	
---	0750.111.341	SHAFT SEAL	1		00.00.0000		105X130X12		8204002990	3	0,000	
170	1315.213.002	COVER	1		00.00.0000		KPL.N151/10			3	0,000	
180	---	HEXAGON BOLT	9		00.00.0000		M8X32			3	0,000	
---	0636.100.798	HEXAGON BOLT	9	Z0000789 1411	01.03.2012	01.03.2012	M8X32			5	0,000	
---	0630.100.295	WASHER	9	Z0000715 8414	30.11.2011	30.11.2011				5	0,000	
190	---	SPACER RING	1		00.00.0000		S= 3,60- 4,40(ABSTUFUNG:0, 10MM)			3	0,000	
---	0730.062.547	SPACER RING	1		00.00.0000		A=4,40 IN 0730 062 546(4)			5	0,000	
---	0730.063.335	SPACER RING	1		00.00.0000		A=4,30 IN 0730 062 546(4)			5	0,000	
---	0730.060.824	SPACER RING	1		00.00.0000		A=4,20 IN 0730 062 546(4)			5	0,000	
---	0730.063.334	SPACER RING	1		00.00.0000		A=4,10 IN 0730 062 546(4)			5	0,000	
---	0730.063.334	SPACER RING	1		00.00.0000		A=4,10 IN 0730 062 546(4)			5	0,000	
---	0730.060.891	SPACER RING	1		00.00.0000		A=4,00 IN 0730 062 546(4)			5	0,000	
---	0730.063.333	SPACER RING	1		00.00.0000		A=3,90 IN 0730 062 546(4)			5	0,000	
---	0730.063.333	SPACER RING	1		00.00.0000		A=3,90 IN 0730 062 546(4)			5	0,000	
---	0730.060.892	SPACER RING	1		00.00.0000		A=3,80 IN 0730 062 546(4)			5	0,000	
---	0730.060.893	SPACER RING	1		00.00.0000		A=3,60 IN 0730 062 546(4)			5	0,000	

VKF Incidence factor

OTK Optional technical kit

ID Identification (output code)

SP Supplier plant



Pos.	Material number	Name	VKF	Amend. no.	Amend. start	Prod. no.	Material feature / tech. info.	OTK	External material no.	ID	Weight	SP
280	0501.315.727	GASKET	1		00.00.0000					5	0,000	
290	1250.313.190	END COVER	1		00.00.0000					5	0,000	
300	0636.016.417	HEXAGON BOLT	4	Z0000797 6515	01.01.2012	01.01.2012	M12X30			5	0,000	

VKF Incidence factor

OTK Optional technical kit

ID Identification (output code)

SP Supplier plant

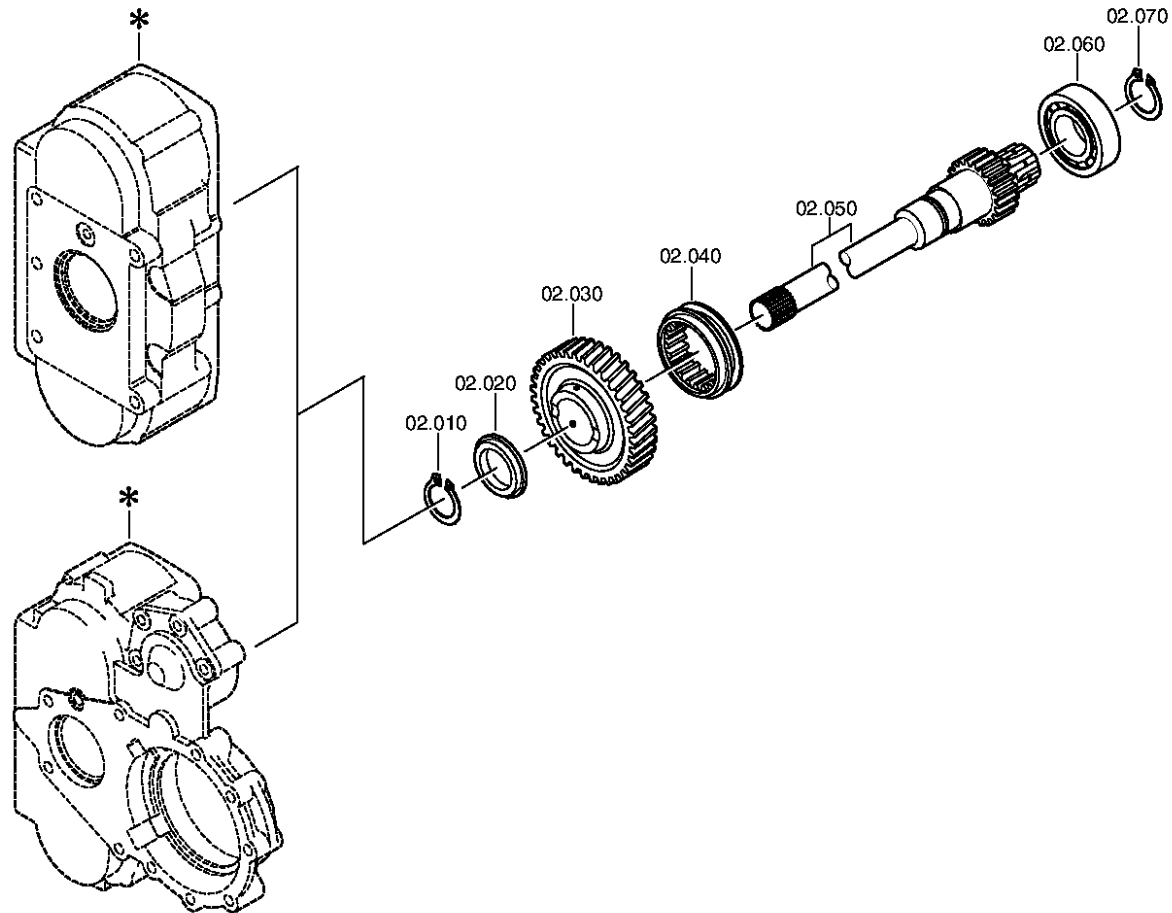



Pos.	Material number	Name	VKF	Amend. no.	Amend. start	Prod. no.	Material feature / tech. info.	OTK	External material no.	ID	Weight	SP
10	---	RETAINING RING	1	C0100150 3A10	00.00.0000	00.00.0000	S= 2,15- 2,40(ABSTUFUNG:0,05MM)			3	0,000	
---	0730.501.275	RETAINING RING	1		00.00.0000		A=2,40 IN 0730 501 271(2)			5	0,000	
---	0730.501.274	RETAINING RING	1		00.00.0000		A=2,35 IN 0730 501 271(2)			5	0,000	
---	0730.501.273	RETAINING RING	1		00.00.0000		A=2,30 IN 0730 501 271(2)			5	0,000	
---	0730.501.272	RETAINING RING	1		00.00.0000		A=2,25 IN 0730 501 271(2)			5	0,000	
---	0730.501.372	RETAINING RING	1		00.00.0000		A=2,20 IN 0730 501 271(2)			5	0,000	
---	0730.501.371	RETAINING RING	1		00.00.0000		A=2,15 IN 0730 501 271(2)			5	0,000	
20	0730.101.140	WASHER	1		00.00.0000		A=11,60 IN 0730 104 460(3)			5	0,000	
30	6091.202.023	INPUT GEAR	1	C0100198 2E10	00.00.0000	00.00.0000	KPL.			3	0,000	
40	1311.313.017	SLIDING SLEEVE	1		00.00.0000		KLAUE D=60			5	0,000	
50	1316.213.001	INPUT SHAFT	1		00.00.0000		KPL.N221/10*N221/10 IT			3	0,000	
/10	1316.313.005	INPUT SHAFT	1		00.00.0000		ENTHALT.IN 1316 313 004(1)			5	0,000	
/20	1250.303.095	THRUST RING	1		00.00.0000					5	0,000	
60	0735.410.139	CYROLLBEARING	1		00.00.0000		40,0X80,0X23,0 FA.SKF			5	0,000	
70	---	RETAINING RING	1	C0100150 3A10	00.00.0000	00.00.0000	S= 2,15- 2,40(ABSTUFUNG:0,05MM)			3	0,000	
---	0730.501.275	RETAINING RING	1		00.00.0000		A=2,40 IN 0730 501 271(2)			5	0,000	
---	0730.501.274	RETAINING RING	1		00.00.0000		A=2,35 IN 0730 501 271(2)			5	0,000	
---	0730.501.273	RETAINING RING	1		00.00.0000		A=2,30 IN 0730 501 271(2)			5	0,000	
---	0730.501.272	RETAINING RING	1		00.00.0000		A=2,25 IN 0730 501 271(2)			5	0,000	
---	0730.501.372	RETAINING RING	1		00.00.0000		A=2,20 IN 0730 501 271(2)			5	0,000	
---	0730.501.371	RETAINING RING	1		00.00.0000		A=2,15 IN 0730 501 271(2)			5	0,000	

VKF Incidence factor

OTK Optional technical kit

ID Identification (output code)

SP Supplier plant

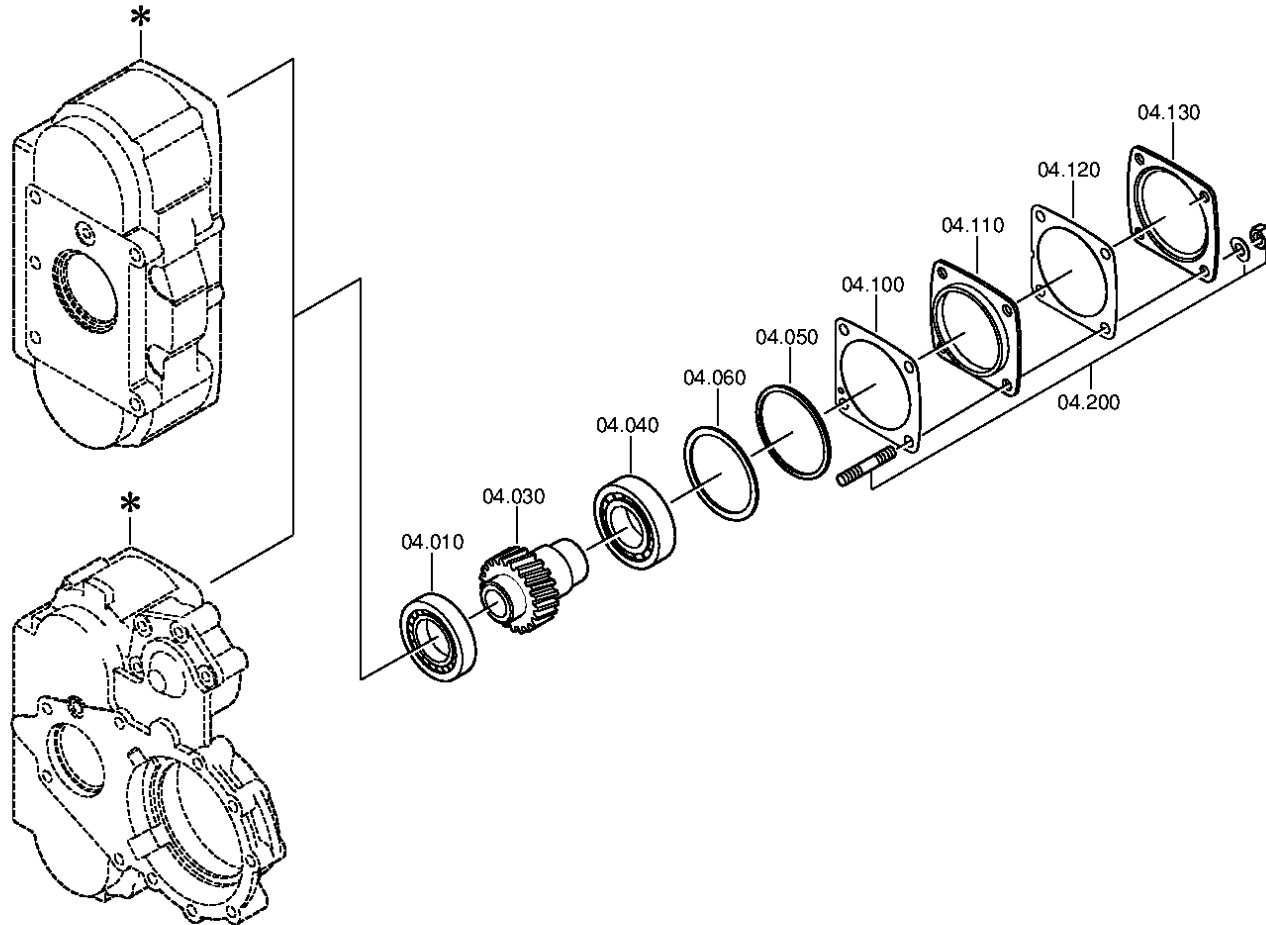



Pos.	Material number	Name	VKF	Amend. no.	Amend. start	Prod. no.	Material feature / tech. info.	OTK	External material no.	ID	Weight	SP
10	0635.373.021	TAROLLBEARING	1		00.00.0000		45X85X24,75		190003326127	5	585	
30	1315.313.037	SPUR GEAR	1		00.00.0000		Z23			5	0,000	
40	0750.117.380	TAROLLBEARING	1		00.00.0000		50,0X90,0X21,7		00-7LZ6258	3	543	
50	0730.003.354	WASHER	1		00.00.0000		A=4,00 IN 0730 003 353(2)			5	0,000	
60	---	SHIM	1		00.00.0000		S= 1,00- 2,00(ABSTUFUNG:0,05MM)			3	0,000	
---	0730.102.777	SHIM	1		00.00.0000		A=2,00 IN 0730 105 456(2)		1276736H1	5	29	
---	0730.102.778	SHIM	1		00.00.0000		A=1,95 IN 0730 105 456(2)		83933825	5	0,020	
---	0730.102.779	SHIM	1		00.00.0000		A=1,90 IN 0730 105 456(2)		1276738H1	5	0,020	
---	0730.102.780	SHIM	1		00.00.0000		A=1,85 IN 0730 105 456(2)			5	0,020	
---	0730.102.781	SHIM	1		00.00.0000		A=1,80 IN 0730 105 456(2)		1276740H1	5	26	
---	0730.102.782	SHIM	1		00.00.0000		A=1,75 IN 0730 105 456(2)			5	0,020	
---	0730.102.783	SHIM	1		00.00.0000		A=1,70 IN 0730 105 456(2)		1276742H1	5	25	
---	0730.102.784	SHIM	1		00.00.0000		A=1,65 IN 0730 105 456(2)			5	24	
---	0730.102.785	SHIM	1		00.00.0000		A=1,60 IN 0730 105 456(2)		1276744H1	5	23	
---	0730.102.786	SHIM	1		00.00.0000		A=1,55 IN 0730 105 456(2)			5	22	
---	0730.102.787	SHIM	1		00.00.0000		A=1,50 IN 0730 105 456(2)		1276746H1	5	22	
---	0730.102.788	SHIM	1		00.00.0000		A=1,45 IN 0730 105 456(2)			5	21	
---	0730.102.789	SHIM	1		00.00.0000		A=1,40 IN 0730 105 456(2)		1276748H1	5	0,020	
---	0730.105.452	SHIM	1		00.00.0000		A=1,35 IN 0730 105 456(2)		83945528	5	20	
---	0730.105.451	SHIM	1		00.00.0000		A=1,30 IN 0730 105 456(2)		104014791	5	0,010	
---	0730.105.450	SHIM	1		00.00.0000		A=1,25 IN 0730 105 456(2)		1276757H1	5	18	
---	0730.106.047	SHIM	1		00.00.0000		A=1,20 IN 0730 105 456(2)			5	0,000	
---	0730.105.449	SHIM	1		00.00.0000		A=1,15 IN 0730 105 456(2)			5	17	
---	0730.105.448	SHIM	1		00.00.0000		A=1,10 IN 0730 105 456(2)		1276755H1	5	16	
---	0730.106.043	SHIM	1		00.00.0000		A=1,05 IN 0730 105 456(2)			5	17	
---	0730.106.041	SHIM	1		00.00.0000		A=1,00 IN 0730 105 456(2)			5	0,000	
100	0501.315.728	GASKET	1		00.00.0000					5	0,000	
110	1296.313.114	CENTERING FLANGE	1		00.00.0000		ENTHALT.IN 1296 313 212(1)			5	0,000	
120	1238.308.201	GASKET	1		00.00.0000		ENTHALT.IN 1238 308 202(2)		5006880	5	0,000	

VKF Incidence factor

OTK Optional technical kit

ID Identification (output code)

SP Supplier plant



Pos.	Material number	Name	VKF	Amend. no.	Amend. start	Prod. no.	Material feature / tech. info.	OTK	External material no.	ID	Weight	SP
130	1328.301.170	COVER	1	Z0000806 8010	31.12.2011	31.12.2011				5	0,000	
200	---	BOLT+NUT	4		00.00.0000		M12X35			3	0,000	
---	0636.604.573	STUD	4	Z0000728 5312	31.12.2011	31.12.2011	M12X35			5	0,000	
---	0730.105.493	WASHER	4		00.00.0000		A=2,00			5	0,000	
---	0737.300.035	HEXAGON NUT	4	Z0000919 6112	31.12.2011	31.12.2011	M12 ERZ. M12			5	0,000	

VKF Incidence factor

OTK Optional technical kit

ID Identification (output code)

SP Supplier plant

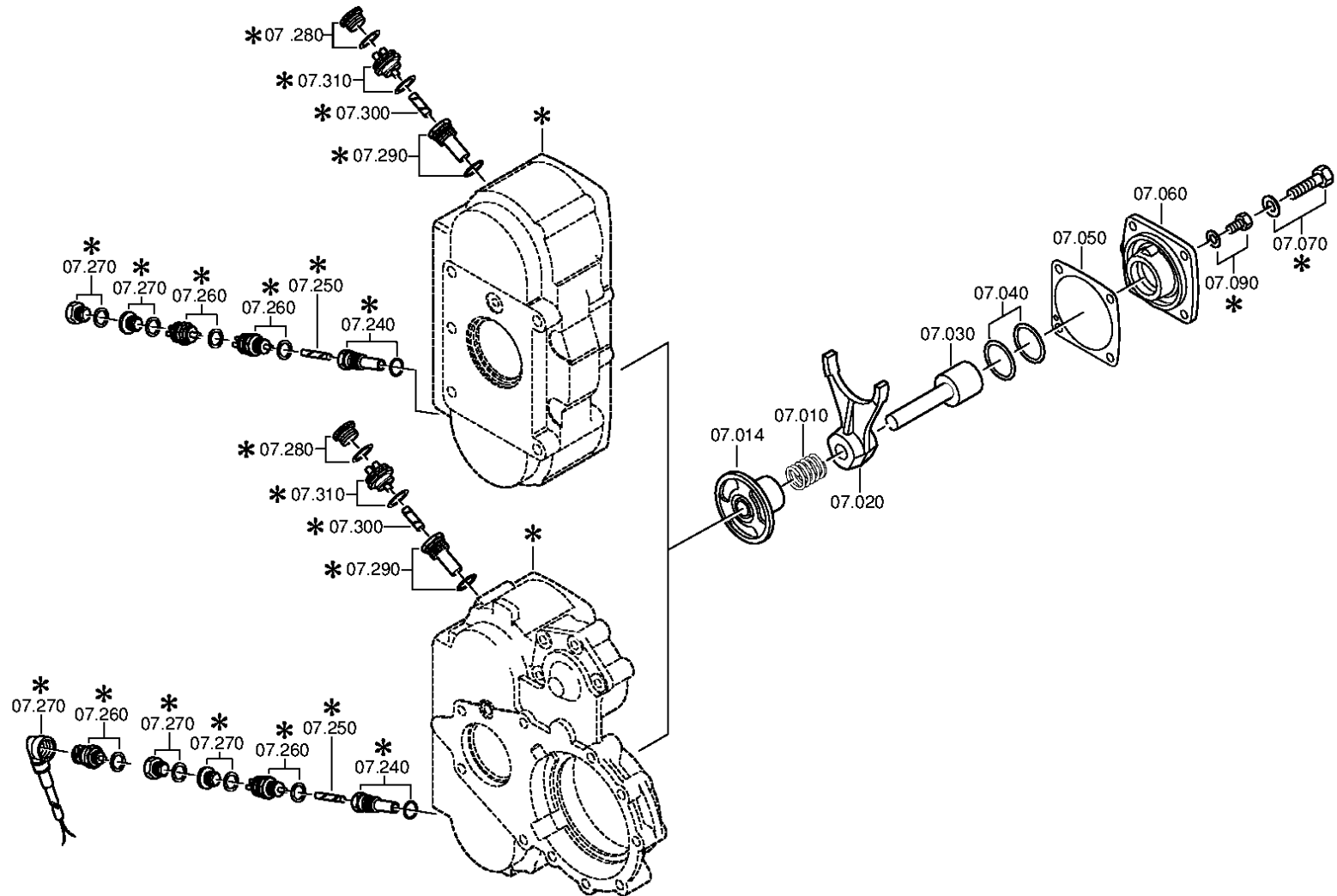



Pos.	Material number	Name	VKF	Amend. no.	Amend. start	Prod. no.	Material feature / tech. info.	OTK	External material no.	ID	Weight	SP
10	0732.041.323	COMPRSPRING	1		00.00.0000				SA 8320-07240	5	43,800	
14	1315.313.077	SPRING BUSH	1	C0100767 8A10	00.00.0000	00.00.0000				5	0,000	
20	1315.313.031	GEAR SHIFT FORK	1		00.00.0000					5	0,000	
30	1315.313.048	PISTON	1		00.00.0000					5	0,000	
40	0634.316.248	O-RING	2		00.00.0000		40X3			5	0,000	
50	0501.315.728	GASKET	1		00.00.0000					5	0,000	
60	1315.313.049	HOUSING	1	C0100908 2B10	00.00.0000	00.00.0000				5	0,000	
70	---	HEXAGON BOLT	4		00.00.0000		M12X35			3	0,000	
---	0636.015.679	HEXAGON BOLT	4		00.00.0000		M12X35			5	0,000	
---	0630.100.284	WASHER	4	Z0000715 8217	01.01.2012	01.01.2012				5	0,000	
240	---	THREADED BUSH	1		00.00.0000		NA-ANZ M26X1,5			3	0,000	
---	1315.313.034	THREADED BUSH	1		00.00.0000		M26X1,5			5	0,000	
---	0634.313.233	O-RING	1		00.00.0000		23X2		9301962	5	0,005	
250	0731.208.151	PIN	1		00.00.0000		A=48,20 IN 0731 208 103(2)			5	0,000	
260	---	SWITCH	1	Z0000428 7211	20.05.2010	20.05.2010	SCHL *45N.M*RING * BAJONETT*SCHUTZKAPPE			3	0,000	
---	0501.210.058	SWITCH	1	Z0000428 7210	20.05.2010	20.05.2010	KPL.		1864900531	5	0,000	
---	0730.150.671	RING	1	Z0000428 7210	20.05.2010	20.05.2010	A=2,00 IN 0730 150 664(3)			5	0,000	
---	0700.300.427	PROTECTING CAP	1	Z0000428 7210	20.05.2010	20.05.2010				5	0,005	
280	---	SCREW PLUG	1	Z0001016 4412	31.12.2011	31.12.2011	70N.M*DICHTRING M26X1,5			3	0,000	
---	0636.100.811	SCREW PLUG	1	Z0001016 4420	25.11.2010	25.11.2010	M26X1,5			5	0,000	
---	0634.801.249	SEALING RING	1	Z0001016 4420	25.11.2010	25.11.2010	26X31			5	0,010	

VKF Incidence factor

OTK Optional technical kit

ID Identification (output code)

SP Supplier plant



Pos.	Material number	Name	VKF	Amend. no.	Amend. start	Prod. no.	Material feature / tech. info.	OTK	External material no.	ID	Weight	SP
910	6091.101.804	HOUSING	1		00.00.0000		N221/10B+C*ABTR.OBEN+ UNTEN*LOSE LIEF+ANBAU			3	0,000	

VKF Incidence factor

OTK Optional technical kit

ID Identification (output code)

SP Supplier plant

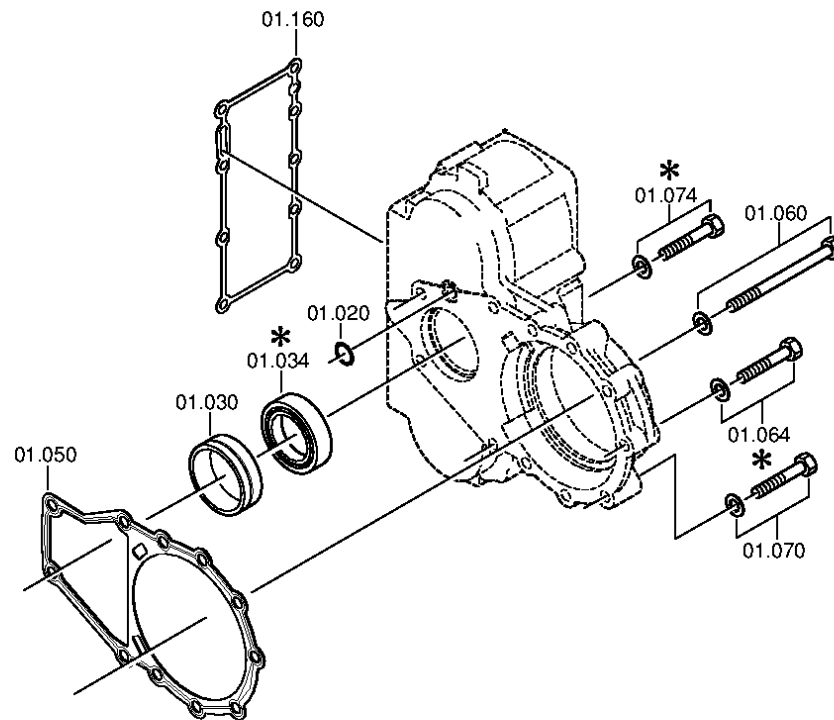

Parts list
Page 1 from 1

Material number: 1341.031.022 16 S 1825 TO /
Plant: 068.64.51-1
Material-assembly-group-no: 6091.101.804



Pos.	Material number	Name	VKF	Amend. no.	Amend. start	Prod. no.	Material feature / tech. info.	OTK	External material no.	ID	Weight	SP
20	0634.313.135	O-RING	1		00.00.0000		15X3			5	0,000	
30	1315.313.055	CENTERING RING	1		00.00.0000					5	0,000	
50	6091.301.045	GASKET	1	C0100202 2D10	00.00.0000	00.00.0000				5	0,000	
60	---	HEXAGON BOLT	2		00.00.0000		M10X125			3	0,000	
---	0636.010.205	HEXAGON BOLT	2		00.00.0000		M10X125			5	0,000	
---	0630.100.294	WASHER	2	Z0000715 8112	31.12.2011	31.12.2011				5	0,000	
64	0636.016.405	HEXAGON BOLT	1	Z0000706 0116	27.01.2011	27.01.2011	M10X60			5	0,000	
70	0636.016.405	HEXAGON BOLT	5	Z0000706 0116	27.01.2011	27.01.2011	M10X60			5	0,000	
74	0636.016.405	HEXAGON BOLT	1	Z0000706 0116	27.01.2011	27.01.2011	M10X60			5	0,000	
160	1315.313.015	GASKET	1	C0100850 0B10	00.00.0000	00.00.0000				5	0,000	

VKF Incidence factor

OTK Optional technical kit

ID Identification (output code)

SP Supplier plant

© All rights reserved by ZF Friedrichshafen AG, even in the event of applications for copyright. We hold all rights of disposal, such as the right to copy and disseminate. All rights reserved.
For information only, not subject to the amendment service.

01.04.2011



Pos.	Information	Amendment number
001	Use case -----	
002	Customer UralAZ Joint Stock Co.	
003	City Miass	
004	DUNS	
005	Product description -----	
006	INSTALLATION POS TRANSMISSION HORIZONTAL LEFT	
007	TRANSMISSION ATTACHMENT FLANGE-MOUNTED	
008	RATIO, BOTTOM GEAR 13.8	
009	RATIO, TOP GEAR .84	
010	RATIO, 1ST GEAR 13.8	
011	RATIO, 2ND GEAR 11.54	
012	RATIO, 3RD GEAR 9.49	
013	RATIO, 4TH GEAR 7.93	
014	RATIO, 5TH GEAR 6.53	
015	RATIO, 6TH GEAR 5.46	
016	RATIO, 7TH GEAR 4.57	
017	RATIO, 8TH GEAR 3.82	
018	RATIO, 9TH GEAR 3.02	
019	RATIO, 10TH GEAR 2.53	
020	RATIO, 11TH GEAR 2.08	
021	RATIO, 12TH GEAR 1.74	
022	RATIO, 13TH GEAR 1.43	
023	RATIO, 14TH GEAR 1.2	
024	RATIO, 15TH GEAR 1	
025	RATIO, 16TH GEAR .84	
026	RATIO, 1ST GEAR REVERSE 12.92	
027	RATIO, 2ND GEAR REVERSE 10.8	
028	SET OF RATIOS SG	
029	UEBERSETZUNGSREIHE BASIS DG	
030	NUMBER OF PLANETARY GEARS 5	
031	UEBERSETZUNG PLANETENSATZ 4.565	
032	AUSF VERZAHNUNG PLANETENSATZ OBLIQUE TOOTHING	



Pos.	Information	Amendment number
033	DESIGN, SHIFT SYSTEM TURNING SHAFT	
034	POSITION, GEAR SHIFT SYSTEM HORIZONTAL LEFT	
035	DESIGN, SHIFT PATTERN H-H	
036	VERSION SHIFT SUPPORT WITHOUT GROOVE	
037	VERSION ACTUATION SHIFT SYSTEM MECHANICAL	
040	VERSION TUBE R/C PLASTIC-FORM-PIPE	
041	VERSION TUBE SERVO WITHOUT PIPING	
043	AUSF RUECKSCHALTG GASSENSPERRE WITHOUT GROOVE	
044	VERSION TUBE GATE INTERLOCK WITHOUT PIPING	
045	1ST CUSTOMER SPEC SHIFT SYSTEM WITHOUT GROOVE	
046	2ND CUSTOMER SPEC SHIFT SYSTEM WITHOUT GROOVE	
047	DIA THROTTLE MAIN CUTOFF VALVE 1.55 mm	
048	NO. TAPPETS MAIN CUTOFF VALVE 2	
049	POS. AIR CON MAIN CUTOFF VALVE F	
052	SELECTION PATTERN VARIANT GEAR SHIFT PATTERN 1	
053	DESIGN, SEPARATING CLUTCH FULL-SYNCHRONIZED	
054	VERSION OF SYNCHRONIZER 1 1.+2.GEAR DK-SYNCHRONIZATION	
055	VERSION OF SYNCHRONIZER 2 3.+4.GEAR BK-SYNCHRONIZATION	
056	REFERENCE LENGTH INPUT SHAFT 109 mm	
057	STANDARD TYPE INPUT SHAFT SAE	
058	NUMBER OF WEDGES INPUT SHAFT 10	
059	VERSION OF INPUT SHAFT FORM C	
060	NOMINAL DIAMETER INPUT SHAFT 2 in	
061	DIAMETER, JOURNAL, INPUT SHAFT 25 mm	
062	TYPE FIT SPIGOTS INPUT SHAFT F7	
063	VER. BEAR. SPIGOTS INPUT SHAFT TAPER ROLLER	
064	LENGTH, INPUT SHAFT 395.5 mm	
065	DIAMETER SHAFT OF INPUT SHAFT 50.3 mm	
066	LENGTH, PROFILE, INPUT SHAFT 120 mm	
067	BUSH VARIANT INPUT SHAFT WITHOUT GROOVE	
068	VERSION BEARING CONSTANT 1 GL	
069	DIAMETER BEARING INPUT SHAFT 99.916 mm	



Pos.	Information	Amendment number
070	TYPE FIT BEAR. INPUT SHAFT H5	
071	DESIGN,CONN., CLUTCH HOUSING SAE 1	
072	CENTR.DIA,HSG/ENGINE CONNECT. 511.175 mm	
073	NUMBER OF BORES,ENGINE CONN. 12	
074	BORE DIA, ENGINE CONNECTION 11 mm	
076	VERSION OF CLUTCH HOUSING INTEGRATED	
077	DESIGN BEARING OUTPUT STANDARD SUSPENSION	
078	VERSION ENGINE CONNECTION NOT FORDABLE	
079	POSITION MOUNT. FACE HOUSING 2 WITHOUT GROOVE	
085	TYPE OF RELEASE MECHANISM WITH	
086	REF.LENGTH,RELEASE BEAR.FLAN -7 mm	
087	DIAMETER, RELEASE FLANGE 60 mm	
088	TYPE FIT RELEASE BEARING FLA. F8	
089	D-LAGERBUCHSE AUSRUECKUNG LI 35 mm	
091	VERSION OF CLUTCH CYLINDER WITH	
092	ASSEMBLY POS. CLUTCH CYLINDER 6	
093	OUTER DIA. OUTPUT FLANGE RA 180 mm	
094	NO.OF BORES OUTPUT FLANGE HA1 4	
096	BORE DIA. OUTPUT FLANGE RA 15 mm	
100	CORROS.PROTECTION, OUTP.FLANGE	
101	REF. LENGTH OUTPUT FLANGE RA 211.5 mm	
102	DIMENSION SHIFT TURRET DIST. 288 mm	
103	MEAS. LOC. SHIFT TURRET DIST. SHIFT LEVER-LOCATION	
110	RADIUS 1 SHIFT LEVER 105 mm	
113	SHIFT LEVER CONNECTION KNURLING	
114	DESIGN, OFFSET, SHIFT LEVER INSIDE	
115	LOCATION GEAR SHIFT LEVER TAPER OUTSIDE	
116	LEVER POSITION SHIFTING OUTPUT A	
117	G.SHIFT LEVER ANGL.EPSILON MIN 34.000 GRAD	
118	G.SHIFT LEVER ANGL.EPSILON MAX 39.000 GRAD	
123	SPRING ARRANGEMENT Q2	
124	SPRING FORCE DETENT PLUNGER RG 150 N	



Pos.	Information	Amendment number
125	HUMP SPRING FORCE, OUTSIDE 120 N	
127	HUMP SPRING FORCE, INSIDE 70.000 N	
128	SELECTOR SPRING FORCE, OUTSIDE 35 N	
129	SELECTOR SPRING FORCE, INSIDE 26 N	
130	SPRING FORCE, GEAR DETENT NG+GG 168 N	
131	SPRING FORCE OUTS. DETENT NEUT 200 N	
133	SWITCH, REVERSE GEAR y	
134	DESIGN, RG (REV.GEAR) SWITCH CLOSING	
135	DESIGN, CONNECTION, RG SWITCH DIN BAYONET	
136	CODE SWITCH RG A1	
137	PROT. CAP SWITCH, REVERSE GEAR y	
138	NOTE ON SWITCH, REVERSE GEAR G.SHIFT SHAFT	
139	SWITCH, NEUTRAL GEAR y	
140	DESIGN, NG (NEUTRAL GEAR) SWITCH OPENING SWITCH	
141	DESIGN, CONNECTION, NG SWITCH DIN BAYONET	
142	CODE SWITCH NG A1	
143	PROT. CAP SWITCH, NEUTRAL GEAR y	
164	FUNCTION OF R/C SWITCH GP	
165	DESIGN, GP SWITCH CLOSING	
166	DESIGN, CONNECTION, GP SWITCH DIN BAYONET	
168	PROTECTING CAP GP SWITCH y	
169	FUNCTION OF S/G SWITCH GV	
170	DESIGN, GV SWITCH OPENING SWITCH	
171	DESIGN, CONNECTION, GV SWITCH DIN BAYONET	
173	PROTECTING CAP GV SWITCH y	
205	ATTACHM.POS.HEAT EXCHANGER IN FRONT LEFT PREPARED	
206	VER. TRANSMISSION VENTILATION PLUG CONNECTION 90 DEGREE	
207	LENGTH, VENT TUBE 2200 mm	
208	POS.TRANSMISSION VENTILATION IN FRONT	
214	VERSION PULSE SENSOR SFA H68	
218	PROT. CAP PULSE SENSOR SFA H68	
219	NO. PULSES PULSE SENSOR SFAH68 6 IMP/U	



Pos.	Information	Amendment number
220	DESIGN PULSE SENSOR SFI H68 WITH	
221	DESIG,CONN,PULSE SENS. SFI H68 DIN BAYONET	
222	PROT.CAP PULSE SENSOR SFI H68 y	
224	VER. PULSE SENSOR TRANSM. H70 WITHOUT GROOVE	
228	PROT. CAP PULSE SENSOR TM H70 n	
229	NO PULSES PULSE SENSOR TM H70 6 IMP/U	
230	ASSEMBLY POS PULSE SENSOR H70 1	
231	NOTE ASS. POS PULSE SENSOR H70 INSTALLATION DRAWING	
243	POSITION, OIL FILLER HOUSING LEFT+RIGHT	
244	NOTE ON OIL FILL FILL IN OVERFLOW	
256	Documents -----	
257	Drawing 1315.051.503	
258	Drawing 1316.101.035	
259	TURN.SHAFT CONT Drawing 1316.172.003	
260	1315.051.203 Drawing 1315.051.203	



Graphics	Pos.	Material number	Name	VKF	Amend. no.	Amend. start	Prod. no.	Material feature / tech. info.	ID
068.01.05-1	110	1315.101.123	GEARBOX HOUSING	1		00.00.0000		DG/SG-KK*W I *FL.OHNE	3
068.01.05-1	120	1315.101.981	GEARBOX HOUSING	1		00.00.0000		DG/SG-KK*ENTL*ROHR	3
068.02.02-1	140	1315.102.439	CONNPLATE	1		00.00.0000		L-7*D60F8*AUSR-WELLE*A-PKT Z H=89*Y H=77	3
068.02.02-1	150	1315.102.811	INPUT SHAFT	1		00.00.0000		A-PLATTE GETR*GEH.6KT-SCHR	3
068.02.02-1	910	1315.102.055	INPUT SHAFT	1		00.00.0000		SG-KK *L109*GL100*ZAPF.25	3
068.03.01-1	180	1316.103.803	LAYSHAFT	1		00.00.0000		PUMPE GETR*GEH.1 6KT-SCHR	3
068.03.01-1	920	1315.103.019	LAYSHAFT	1		00.00.0000		16S151*SG-KK*LAGER 43,6 *ZW- PROFIL	3
068.04.12-1	930	1315.104.027	MAIN SHAFT	1		00.00.0000		16S151*SG-KK+DG NEUES K.K *GP- SV*HS45	3
068.06.01-1	230	1315.106.008	GEAR SHIFT SYSTEM	1		00.00.0000		WL*W I	3
068.06.01-1	234	1315.106.422	CONNECTING PARTS	1		00.00.0000		GEH.2 W I RG/HG-VERSCHL	3
068.06.01-1	238	1315.106.800	GEAR SHIFT SYSTEM	1		00.00.0000		GLEITSTEINE 1-4GANG *SCHALTSCHIENE VERSTIFTET	3
068.07.08-1	282	1315.107.851	GEAR SHIFT HOUSING	1		00.00.0000		WL*H-H*SCHUTZKAPPE *R=105 *A38*FYO*O.SCHR.ST	3
068.07.08-1	910	1316.107.035	GEAR SHIFT HOUSING	1		00.00.0000		WL*W I*RAENDEL	3
068.07.08-1	914	1316.107.434	GEAR SHIFT SHAFT	1		00.00.0000		W I*H-H*HASV 2-ST*D=1,55 *RASTE 200N*NG-BUEGEL 1315/1316	3
068.07.08-1	920	1316.107.031	CONNECTING PARTS	1		00.00.0000		RG-RASTE SEPARAT*150N	3
068.08.06-1	926	1316.170.001	SHIFT TURRET	1		00.00.0000		WL	3
068.08.06-1	930	1316.170.031	COVER	1		00.00.0000		WL*H-H *VM	3
068.08.06-1	934	1316.170.815	COVER	1		00.00.0000		WL*AUSL+GEH*H-H*HF120N *HF I 70N	3
068.08.06-1	938	1316.170.442	CONNECTING PARTS	1		00.00.0000		WL*NG-OEFF*RG-SCHL*168N *BAJONETT	3
068.12.02-1	922	1316.149.010	SET OF SPRINGS	1		00.00.0000		WL/WR*Q2/Q3*WF 35*I=26N	3
068.40.04-1	500	1315.112.014	GV-SHIFT SYSTEM	1		00.00.0000		235N*GV-LAG.GEH.1*KURZ	3
068.40.04-1	502	1315.112.422	CONNECTING PARTS	1		00.00.0000		SG*GV-OEFF*BAJONETT	3

VKF Incidence factor

ID Identification (output code)



Graphics	Pos.	Material number	Name	VKF	Amend. no.	Amend. start	Prod. no.	Material feature / tech. info.	ID
068.43.05-1	20	1315.131.037	GP HOUSING	1		00.00.0000		16S151/221*N10*N10-PL*ET *O.GP-LUFTKANAL	3
068.43.05-1	512	1315.131.805	GP HOUSING	1		00.00.0000			3
068.43.05-1	516	1315.131.412	CONNECTING PARTS	1		00.00.0000		IMPULSGEBER ET H68 *BAJONETT*E-TACHO-SEITL	3
068.44.07-1	40	1315.132.015	PLANETARY DRIVE	1		00.00.0000		4,565*GP-SV*FL.PROF.90	3
068.44.07-1	50	1316.132.419	PLANETARY DRIVE	1	C01004618F1	00.00.0000		180*LZ= 4*D=15,0*L=211,5 *RVI*FLANSCH BESCHICHTET	3
068.45.04-1	70	1316.133.008	SYNCHRONIZER	1		00.00.0000		MOLYB*FL-PROFIL 90*E/Z6-V *GP-SV*16S151/221	3
068.45.04-1	80	1315.133.405	SYNCHRONIZER	1	C01001743F1	00.00.0000		FL-PROFIL 80 GV-GP 16 S151*FL-PROFIL 90 SV-GP 16 S151-251	3
068.46.03-1	90	1315.134.015	GP SHIFT SYSTEM	1	C01001743F1	00.00.0000		SCHIENE KURZ*GP-ANZ.SCHLT	3
068.46.03-1	554	1315.134.413	CONNECTING PARTS	1		00.00.0000		145N*GP-SCHL*BAJONETT *GV-LAG	3
068.57.04-1	390	1315.145.004	RANGE SELECTION	1		00.00.0000		16S151 *VORGEFORMTE ROHRE	3
068.93.13-1	130	1315.168.030	CLUTCH RELEASE DEVICE	1		00.00.0000		AUSR-WELLE*SW=78 *HINO	3
068.93.13-1	132	1315.168.426	CLUTCH RELEASE DEVICE	1		00.00.0000		ZYL*SERVO LUFTABSCHALTUNG *D=100*HUB=75*STOESSEL L=145	3

VKF Incidence factor

ID Identification (output code)

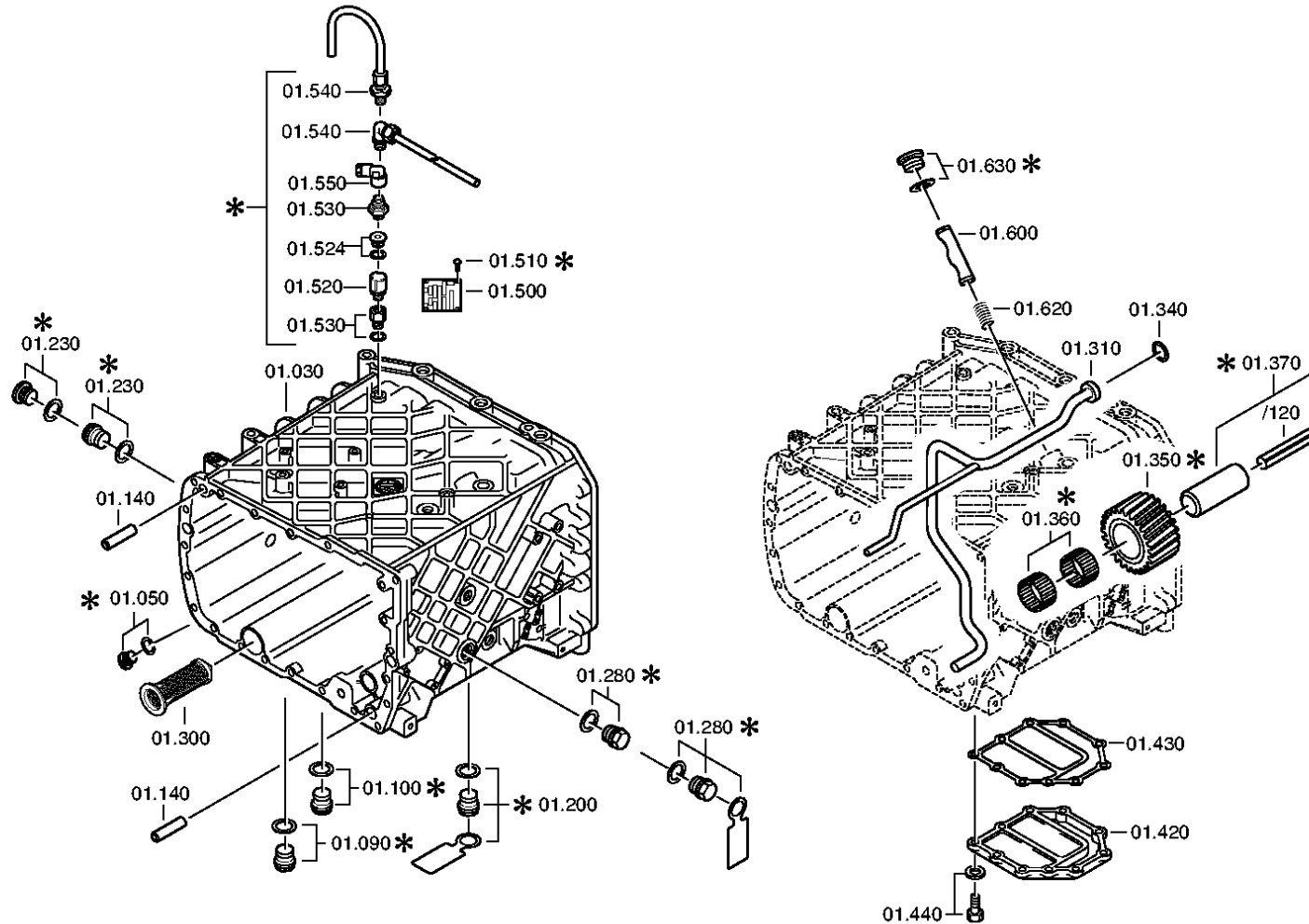

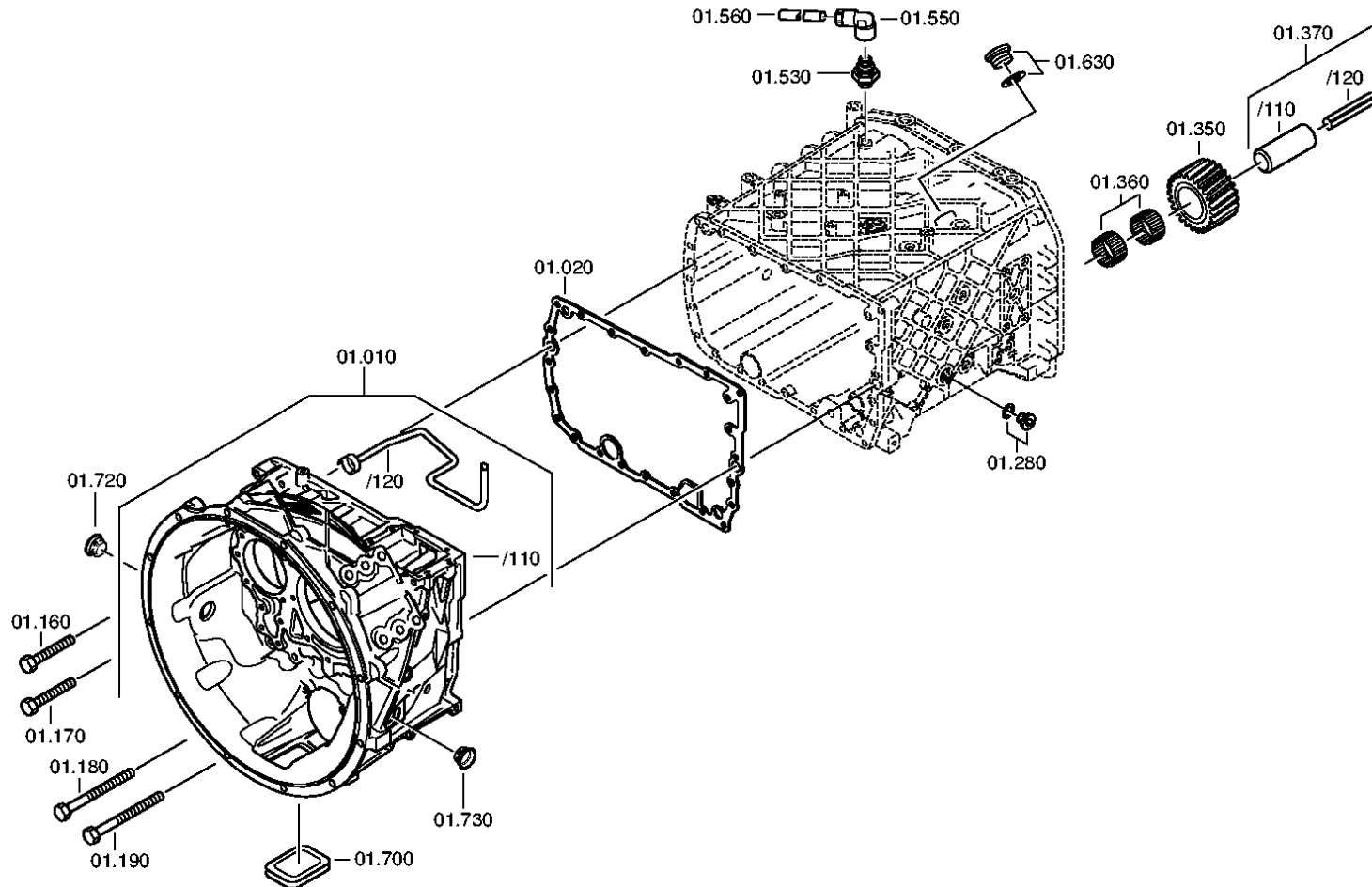



Pos.	Material number	Name	VKF	Amend. no.	Amend. start	Prod. no.	Material feature / tech. info.	OTK	External material no.	ID	Weight	SP
10	1316.201.142	CLUTCH HOUSING	1		00.00.0000		KPL.			3	0,000	
/110	1316.301.064	CLUTCH HOUSING	1		00.00.0000		ENTHALT.IN 1316 301 060(0)			5	0,000	
/120	1315.201.097	PIPE	1		00.00.0000		KPL.			3	0,000	
20	1315.301.233	GASKET	1	C0100534 8C10	00.00.0000	00.00.0000				5	0,000	
30	1315.201.208	HOUSING	1		00.00.0000		KPL.			3	0,000	
50	---	SCREW PLUG	1	Z0001017 6111	07.11.2011	07.11.2011	24X1,5			3	0,000	
---	0736.300.160	SCREW PLUG	1	Z0001017 6110	25.11.2010	25.11.2010	M24X1,5 M24X1,5			5	0,000	
---	0730.008.637	SEALING RING	1	Z0001017 6110	25.11.2010	25.11.2010	A24X29			5	0,000	
90	---	SCREW PLUG	1	Z0001016 4013	01.01.2012	01.01.2012	50N.M*DICHTRING M22X1,5			3	0,000	
---	0636.100.824	SCREW PLUG	1	Z0001016 4019	01.12.2010	01.12.2010	M22X1,5			5	0,000	
---	0730.009.515	SEALING RING	1	Z0001016 4019	01.12.2010	01.12.2010	A22X27			5	0,000	
100	---	SCREW PLUG	1	Z0001016 4013	01.01.2012	01.01.2012	50N.M*DICHTRING M22X1,5			3	0,000	
---	0636.100.824	SCREW PLUG	1	Z0001016 4019	01.12.2010	01.12.2010	M22X1,5			5	0,000	
---	0730.009.515	SEALING RING	1	Z0001016 4019	01.12.2010	01.12.2010	A22X27			5	0,000	
140	0731.201.563	CYLINDRICAL PIN	4		00.00.0000					5	0,000	
160	0736.300.123	HEXAGON BOLT	14		00.00.0000		M10X70 M10X70			5	0,000	
170	---	HEXAGON BOLT	1		00.00.0000		M10X70			3	0,000	
---	0736.300.123	HEXAGON BOLT	1		00.00.0000		M10X70 M10X70			5	0,000	
---	0666.790.033	SEALCOMPOUND	1		00.00.0000					5	0,310	
180	0736.300.119	HEXAGON BOLT	6	Z0000940 3410	31.12.2011	31.12.2011	M10X140 M10X140			5	0,000	

VKF Incidence factor

OTK Optional technical kit

ID Identification (output code)

SP Supplier plant



Pos.	Material number	Name	VKF	Amend. no.	Amend. start	Prod. no.	Material feature / tech. info.	OTK	External material no.	ID	Weight	SP
190	---	HEXAGON BOLT	1	Z0000940 3410	31.12.2011	31.12.2011	M10X140			3	0,000	
---	0736.300.119	HEXAGON BOLT	1	Z0000940 3412	08.12.2010	08.12.2010	M10X140 M10X140			5	0,000	
---	0666.790.033	SEALCOMPOUND	1	Z0000940 3412	08.12.2010	08.12.2010				5	0,310	
200	---	SCREW PLUG	1	Z0001011 2111	31.12.2011	31.12.2011	60N.M*DICHTRING M24X1,5			3	0,000	
---	0636.304.088	SCREW PLUG	1	Z0001011 2110	24.11.2010	24.11.2010	M24X1,5			5	0,000	
---	0730.008.637	SEALING RING	1	Z0001011 2110	24.11.2010	24.11.2010	A24X29			5	0,000	
230	---	SCREW PLUG	1	Z0001011 2111	31.12.2011	31.12.2011	60N.M*DICHTRING M24X1,5			3	0,000	
---	0636.304.088	SCREW PLUG	1	Z0001011 2110	24.11.2010	24.11.2010	M24X1,5			5	0,000	
---	0730.008.637	SEALING RING	1	Z0001011 2110	24.11.2010	24.11.2010	A24X29			5	0,000	
280	---	SCREW PLUG	1	Z0001011 2111	31.12.2011	31.12.2011	60N.M*DICHTRING M24X1,5			3	0,000	
---	0636.304.088	SCREW PLUG	1	Z0001011 2110	24.11.2010	24.11.2010	M24X1,5			5	0,000	
---	0730.008.637	SEALING RING	1	Z0001011 2110	24.11.2010	24.11.2010	A24X29			5	0,000	
300	0501.318.802	SCREEN INSERT	1		00.00.0000				5718 742 08	5	0,000	
310	1315.201.111	SPRAY TUBE	1		00.00.0000		KPL. IN 1315 201 112(0)			3	0,000	
340	0634.313.198	O-RING	1		00.00.0000		20X3		1000004936	5	1	
350	1315.305.011	REVERSE IDLER GEAR	1	C0100006 2F10	00.00.0000	00.00.0000				5	0,000	
360	0750.115.366	NEEDLE CAGE	2		00.00.0000		45,0X57,0X21,0			3	0,000	
370	1315.201.053	REVERSE IDLER SHAFT	1		00.00.0000		KPL.16S151*DG*L=84			3	0,000	

VKF Incidence factor

OTK Optional technical kit

ID Identification (output code)

SP Supplier plant



Pos.	Material number	Name	VKF	Amend. no.	Amend. start	Prod. no.	Material feature / tech. info.	OTK	External material no.	ID	Weight	SP
/120	0631.329.294	SLOTPIN	1		00.00.0000		10X100			5	0,000	
420	1315.301.151	COVER	1		00.00.0000					5	0,000	
430	0501.316.146	GASKET	1		00.00.0000				133-198-1940	5	0,000	
440	0636.100.432	HEXAGON BOLT	10	Z0000734 9511	01.01.2012	01.01.2012	M10X28			5	0,000	
500	---	TYPE PLATE	1		00.00.0000		KONZERN			3	0,000	
---	0730.365.241	TYPE PLATE	1		00.00.0000		EINHEITSSCH. VERDREHSICHER			5	0,000	
---	0730.365.259	TYPE PLATE	1		00.00.0000		EINHEITSSCH. VERDREHSICHER			5	0,000	
---	0730.365.267	TYPE PLATE	1		00.00.0000		CHINA			5	0,000	
---	0730.300.258	TYPE PLATE	1		00.00.0000		EINHEITSSCH. VERDREHSICHER			5	0,000	
---	0730.365.271	TYPE PLATE	1		00.00.0000		RUSSLAND/ KYRILLISCH			5	0,000	
---	0730.365.257	TYPE PLATE	1		00.00.0000		S.S.CH IRAN			5	0,000	
510	0731.300.027	BLIND RIVET	4	Z0000790 4810	01.01.2012	01.01.2012				5	0,000	
530	0501.315.794	CANNON SOCKET	1	Z0000636 6310	29.01.2010	29.01.2010	VOSS M10X1			5	0,000	
560	1315.201.214	PIPE	1		00.00.0000		L=2200MM			3	0,000	
600	1313.306.013	LOCKING PIN	1		00.00.0000					5	0,000	
620	0732.040.736	COMPRSPRING	1		00.00.0000				2150041300	5	5,200	
630	---	SCREW PLUG	1	Z0001016 4412	31.12.2011	31.12.2011	70N.M*DICHTRING M26X1,5			3	0,000	
---	0636.100.811	SCREW PLUG	1	Z0001016 4420	25.11.2010	25.11.2010	M26X1,5			5	0,000	
---	0634.801.249	SEALING RING	1	Z0001016 4420	25.11.2010	25.11.2010	26X31			5	0,010	
700	1315.301.230	PROTECTION CAP	1		00.00.0000					5	0,000	
720	0501.321.840	PLUG	1		00.00.0000					5	0,000	
730	0501.321.840	PLUG	1		00.00.0000					5	0,000	

VKF Incidence factor

OTK Optional technical kit

ID Identification (output code)

SP Supplier plant

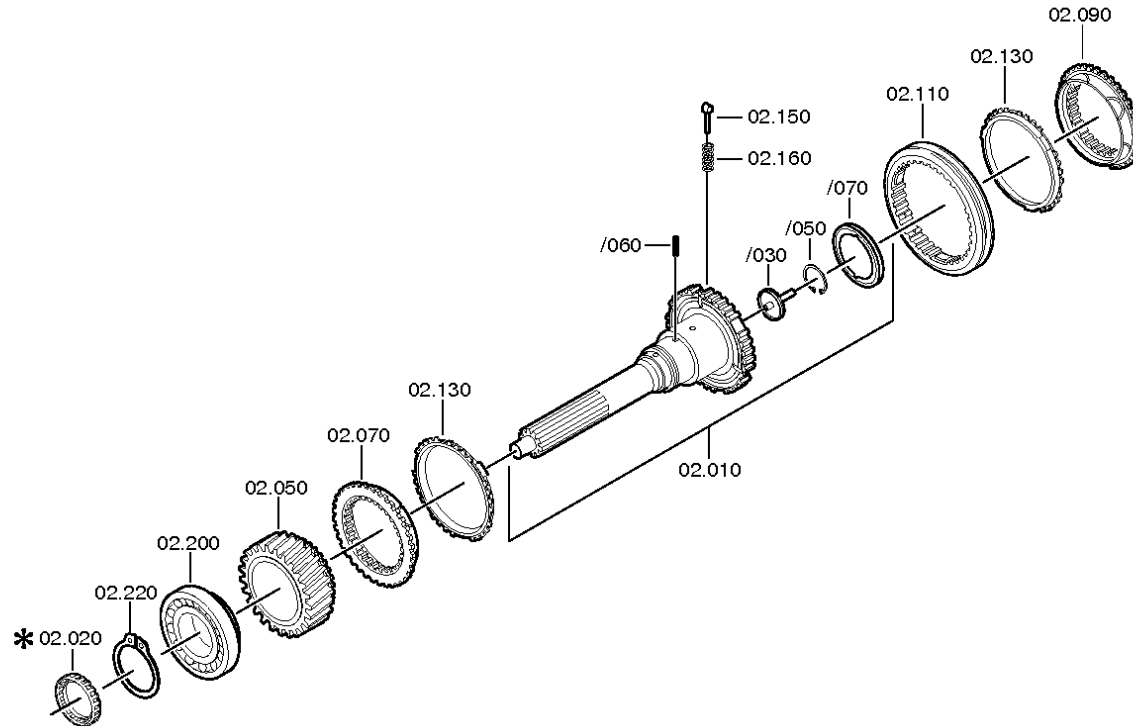

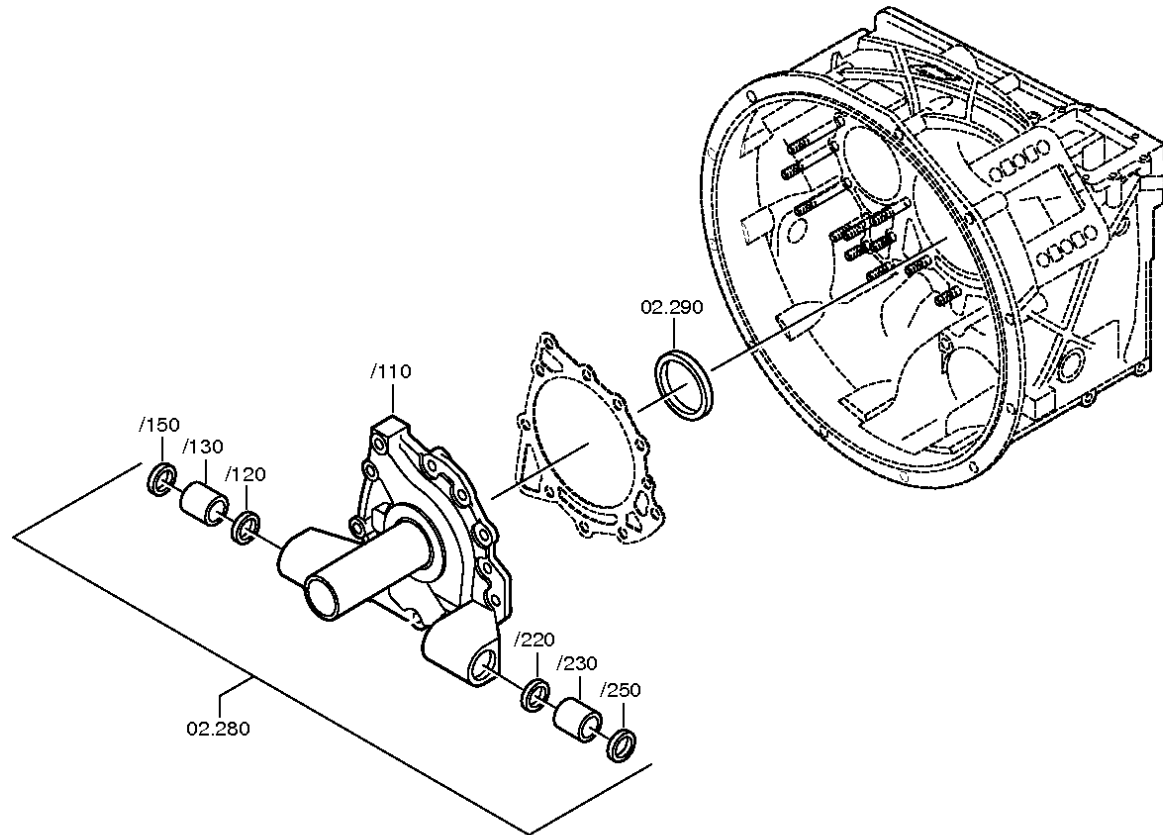

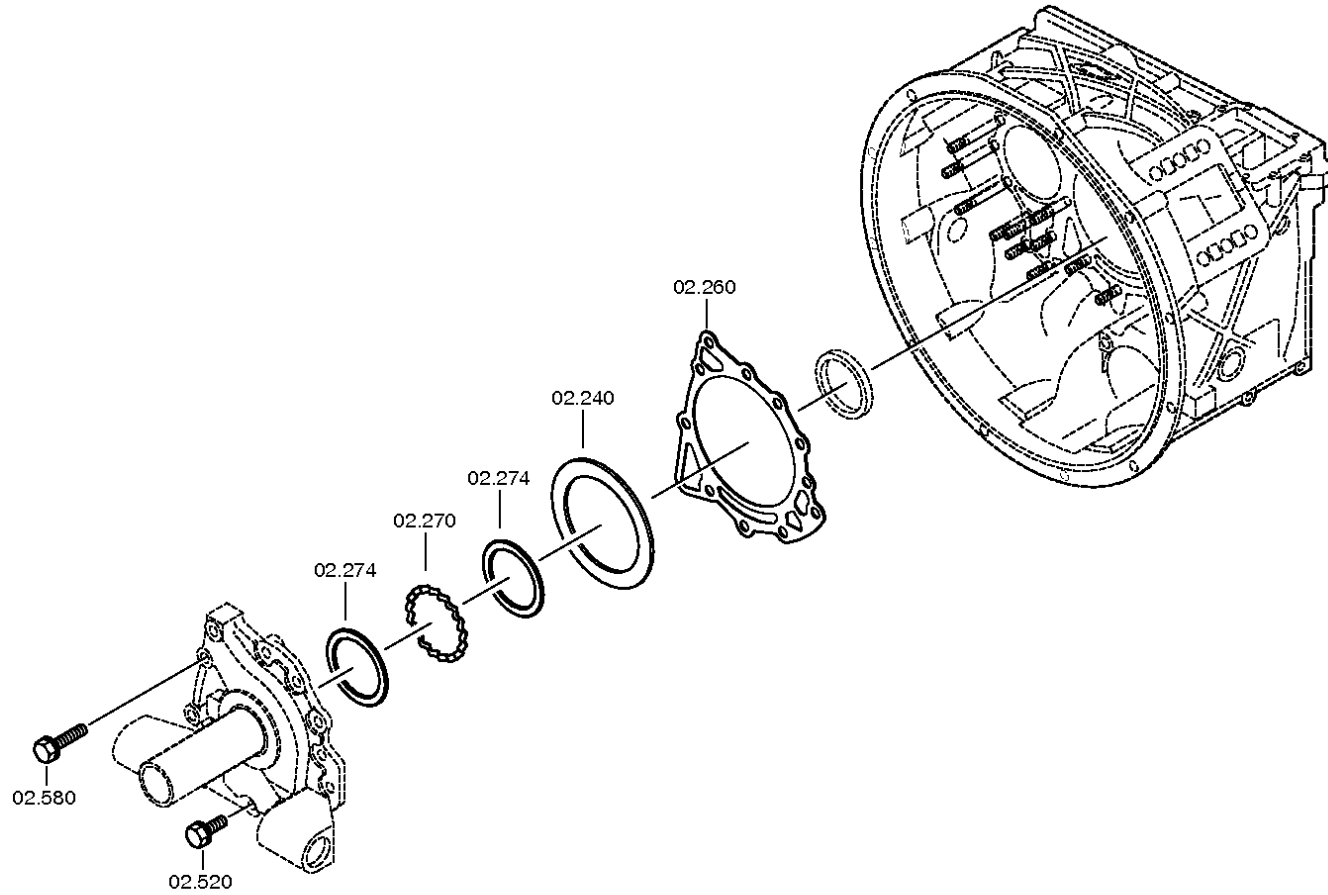



Pos.	Material number	Name	VKF	Amend. no.	Amend. start	Prod. no.	Material feature / tech. info.	OTK	External material no.	ID	Weight	SP
10	1315.202.037	INPUT SHAFT	1		00.00.0000		KPL.L109*GL100*ZAPF.25			3	0,000	
/30	1354.302.019	PIPE	1	Z0000383 0511	31.12.2010	31.12.2010				5	0,000	
/50	0630.502.027	RETAINING RING	1		00.00.0000		50X2			5	8	
/70	0750.101.179	OIL DAM	1	Z0000718 7910	20.05.2010	20.05.2010	88,0X95,5X6,0			3	0,000	
50	1315.302.158	HELICAL GEAR	1		00.00.0000		Z35 IN 1315 302 156(1)			5	0,000	
70	1312.304.027	CLUTCH BODY	1		00.00.0000		ENTHALT.IN 1310 304 107(1)		133-461-3080	5	0,000	
90	1312.304.027	CLUTCH BODY	1	C0100468 0D10	00.00.0000	00.00.0000	ENTHALT.IN 1310 304 107(1)		133-461-3080	5	0,000	
110	1310.304.202	SLIDING SLEEVE	1	C0100537 8A10	00.00.0000	00.00.0000			133-421-3670	5	0,000	
130	1297.304.484	SYNCHRO RING	2		00.00.0000				133-441-1580	5	0,000	
150	1297.304.436	PRESSURE PIECE	3		00.00.0000					5	0,004	
160	0732.040.409	COMPRSPRING	3	C0100731 7F10	00.00.0000	00.00.0000				5	0,002	
200	0750.117.732	TAROLLBEARING	1		00.00.0000		85,0X150,0X30,5		820-400-2350	3	0,000	
220	0730.501.598	RETAINING RING	1	C0100799 2110	00.00.0000	00.00.0000	85X4			5	0,000	
240	---	SHIM	1		00.00.0000		S= 0,90- 2,20(ABSTUFUNG:0,05MM)			3	0,000	
---	2050.309.094	SHIM	1		00.00.0000		A=2,2 IN 2050 309 090 C45E WW.F500 ZFN410			5	0,000	
---	0730.007.489	SHIM	1		00.00.0000		A=2,15 IN 2050 309 090(2)			5	0,000	
---	0730.007.488	SHIM	1		00.00.0000		A=2,10 IN 2050 309 090(2)			5	0,000	
---	0730.007.487	SHIM	1		00.00.0000		A=2,05 IN 2050 309 090(2)			5	0,000	
---	0730.007.486	SHIM	1		00.00.0000		A=2,00 IN 2050 309 090(2)			5	0,000	
---	0730.007.485	SHIM	1		00.00.0000		A=1,95 IN 2050 309 090(2)			5	0,000	
---	0730.007.484	SHIM	1		00.00.0000		A=1,90 IN 2050 309 090(2)			5	0,000	
---	0730.007.483	SHIM	1		00.00.0000		A=1,85 IN 2050 309 090(2)			5	0,000	
---	0730.007.482	SHIM	1		00.00.0000		A=1,80 IN 2050 309 090(2)			5	0,000	

VKF Incidence factor

OTK Optional technical kit

ID Identification (output code)

SP Supplier plant



Pos.	Material number	Name	VKF	Amend. no.	Amend. start	Prod. no.	Material feature / tech. info.	OTK	External material no.	ID	Weight	SP
---	0730.007.481	SHIM	1		00.00.0000		A=1,75 IN 2050 309 090(2)			5	0,000	
---	0730.007.480	SHIM	1		00.00.0000		A=1,70 IN 2050 309 090(2)		1833896	5	0,000	
---	0730.007.479	SHIM	1		00.00.0000		A=1,65 IN 2050 309 090(2)			5	0,000	
---	0730.007.136	SHIM	1		00.00.0000		A=1,60 IN 2050 309 090(2)			5	0,000	
---	0730.007.135	SHIM	1		00.00.0000		A=1,55 IN 2050 309 090(2)			5	0,000	
---	0730.007.134	SHIM	1		00.00.0000		A=1,50 IN 2050 309 090(2)			5	0,000	
---	0730.007.133	SHIM	1		00.00.0000		A=1,45 IN 2050 309 090(2)			5	0,000	
---	0730.007.132	SHIM	1		00.00.0000		A=1,40 IN 2050 309 090(2)			5	0,000	
---	0730.007.131	SHIM	1		00.00.0000		A=1,35 IN 2050 309 090(2)			5	0,000	
---	0730.007.130	SHIM	1		00.00.0000		A=1,30 IN 2050 309 090(2)			5	0,000	
---	0730.007.129	SHIM	1		00.00.0000		A=1,25 IN 2050 309 090(2)			5	0,000	
---	2050.309.034	SHIM	1		00.00.0000		A=1,2 IN 2050 309 090 C45E WW.F500 ZFN410			5	0,000	
---	0730.007.128	SHIM	1		00.00.0000		A=1,15 IN 2050 309 090(2)			5	0,000	
---	0730.007.127	SHIM	1		00.00.0000		A=1,10 IN 2050 309 090(2)			5	0,000	
---	0730.007.126	SHIM	1		00.00.0000		A=1,05 IN 2050 309 090(2)			5	0,000	
---	2050.309.065	SHIM	1		00.00.0000		A=1,0 IN 2050 309 090 C45E WW.F500 ZFN410			5	0,000	
---	0730.005.749	SHIM	1		00.00.0000		A=0,95 IN 2050 309 090(2)			5	0,000	
---	0730.005.748	SHIM	1		00.00.0000		A=0,90 IN 2050 309 090(2)			5	0,000	
260	0501.314.587	GASKET	1		00.00.0000				133-188-2550	5	0,000	
270	1315.302.040	SPACER RING	1		00.00.0000					5	0,000	
274	0730.150.766	WASHER	2		00.00.0000					5	0,000	
280	1315.202.068	CONNPLATE	1		00.00.0000		KPL.			3	0,000	
/130	0730.260.398	BUSH	1		00.00.0000		A=25,00			5	0,000	
/230	0730.260.398	BUSH	1		00.00.0000		A=25,00			5	0,000	
290	---	SHAFT SEAL	1	C0100211 1D10	00.00.0000	00.00.0000	75X55X8			3	0,000	
---	0734.310.387	SHAFT SEAL	1		00.00.0000		55X75X8/9,2 FA.CFW			5	0,000	
520	0636.015.685	HEXAGON BOLT	8	Z0000917 7310	01.01.2012	01.01.2012	M10X35			5	0,000	

VKF Incidence factor

OTK Optional technical kit

ID Identification (output code)

SP Supplier plant



Pos.	Material number	Name	VKF	Amend. no.	Amend. start	Prod. no.	Material feature / tech. info.	OTK	External material no.	ID	Weight	SP
580	0636.102.270	HEXAGON BOLT	3	Z0000917 7410	25.07.2011	25.07.2011	M10X60			5	0,000	

VKF Incidence factor

OTK Optional technical kit

ID Identification (output code)

SP Supplier plant

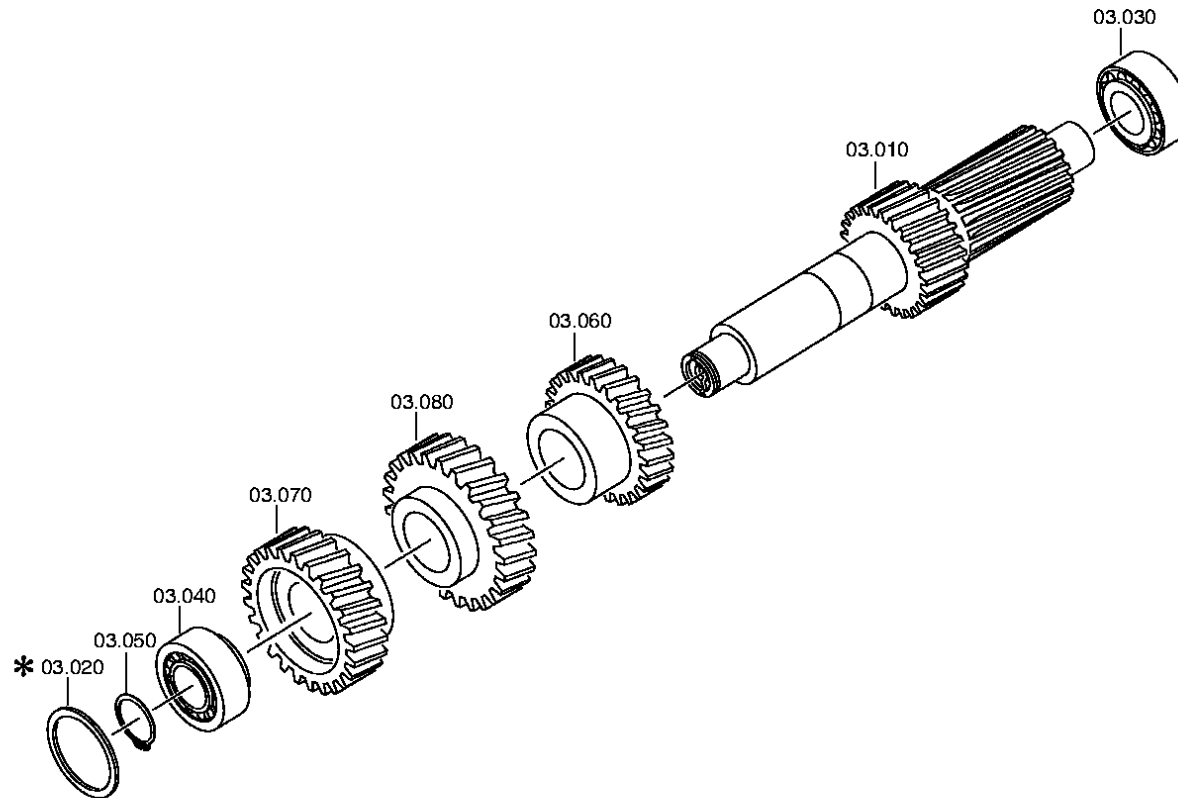

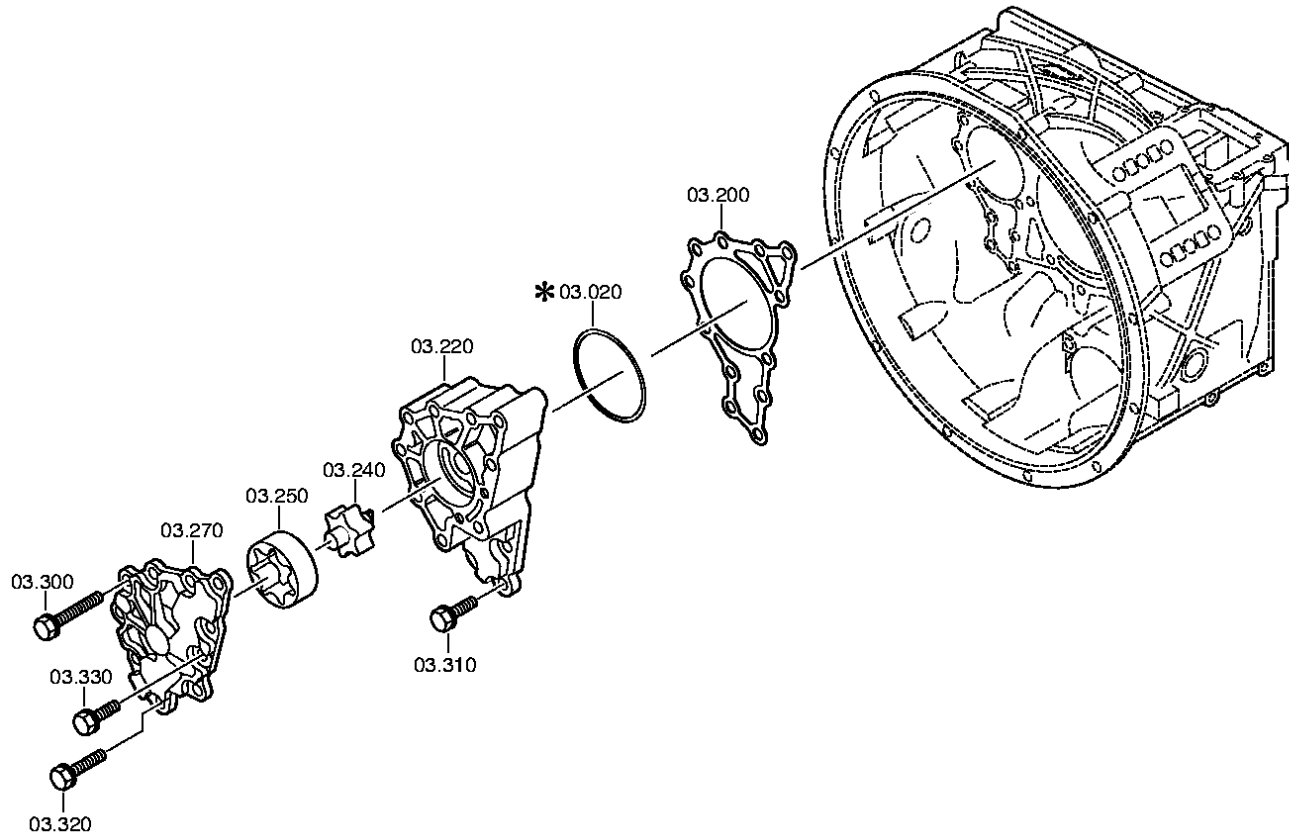



Pos.	Material number	Name	VKF	Amend. no.	Amend. start	Prod. no.	Material feature / tech. info.	OTK	External material no.	ID	Weight	SP
10	1315.303.063	LAYSHAFT	1		00.00.0000					5	0,000	
20	---	SHIM	1		00.00.0000		S= 1,85- 3,25(ABSTUFUNG:0,05MM)			3	0,000	
---	0730.112.938	SHIM	1	C0100737 5C10	00.00.0000	00.00.0000	A=3,25			5	0,000	
---	0730.112.937	SHIM	1	C0100737 5C10	00.00.0000	00.00.0000	A=3,20			5	0,000	
---	0730.112.936	SHIM	1	C0100737 5C10	00.00.0000	00.00.0000	A=3,15			5	0,000	
---	0730.112.935	SHIM	1	C0100737 5C10	00.00.0000	00.00.0000	A=3,10			5	0,000	
---	0730.106.860	SHIM	1	C0100737 5C10	00.00.0000	00.00.0000	A=3,05 IN 0730 106 904(2)			5	0,000	
---	0730.106.917	SHIM	1		00.00.0000		A=3,00 IN 0730 106 904(2)			5	0,000	
---	0730.106.916	SHIM	1		00.00.0000		A=2,95 IN 0730 106 904(2)		1833921	5	0,000	
---	0730.106.915	SHIM	1		00.00.0000		A=2,90 IN 0730 106 904(2)		1833920	5	0,000	
---	0730.106.914	SHIM	1		00.00.0000		A=2,85 IN 0730 106 904(2)		1833919	5	0,000	
---	0730.106.913	SHIM	1		00.00.0000		A=2,80 IN 0730 106 904(2)		1833918	5	0,000	
---	0730.106.912	SHIM	1		00.00.0000		A=2,75 IN 0730 106 904(2)			5	0,000	
---	0730.106.911	SHIM	1		00.00.0000		A=2,70 IN 0730 106 904(2)		1833917	5	0,000	
---	0730.106.910	SHIM	1		00.00.0000		A=2,65 IN 0730 106 904(2)		1833916	5	0,000	
---	0730.106.909	SHIM	1		00.00.0000		A=2,60 IN 0730 106 904(2)		1833915	5	0,000	
---	0730.106.908	SHIM	1		00.00.0000		A=2,55 IN 0730 106 904(2)		1833914	5	0,000	
---	0730.100.799	SHIM	1		00.00.0000		A=2,50 IN 0730 106 904(2)			5	0,000	
---	0730.100.800	SHIM	1		00.00.0000		A=2,45 IN 0730 106 904(2)		1833898	5	0,000	
---	0730.100.801	SHIM	1		00.00.0000		A=2,40 IN 0730 106 904(2)			5	0,000	
---	0730.100.802	SHIM	1		00.00.0000		A=2,35 IN 0730 106 904(2)		1833900	5	0,000	
---	0730.100.803	SHIM	1		00.00.0000		A=2,30 IN 0730 106 904(2)		1833905	5	0,000	
---	0730.101.466	SHIM	1		00.00.0000		A=2,25 IN 0730 106 904(2)			5	0,000	
---	0730.101.467	SHIM	1		00.00.0000		A=2,20 IN 0730 106 904(2)		1833906	5	0,000	
---	0730.101.468	SHIM	1		00.00.0000		A=2,15 IN 0730 106 904(2)		1833907	5	0,000	

VKF Incidence factor

OTK Optional technical kit

ID Identification (output code)

SP Supplier plant



Pos.	Material number	Name	VKF	Amend. no.	Amend. start	Prod. no.	Material feature / tech. info.	OTK	External material no.	ID	Weight	SP
---	0730.101.469	SHIM	1		00.00.0000		A=2,10 IN 0730 106 904(2)		1833909	5	0,000	
---	0730.101.470	SHIM	1		00.00.0000		A=2,05 IN 0730 106 904(2)		1833910	5	0,000	
---	0730.101.471	SHIM	1		00.00.0000		A=2,00 IN 0730 106 904(2)			5	0,000	
---	0730.106.907	SHIM	1		00.00.0000		A=1,95 IN 0730 106 904(2)		1833912	5	0,000	
---	0730.106.906	SHIM	1		00.00.0000		A=1,90 IN 0730 106 904(2)		1833911	5	0,000	
---	0730.106.905	SHIM	1		00.00.0000		A=1,85 IN 0730 106 904(2)			5	0,000	
30	0750.117.009	TAROLLBEARING	1		00.00.0000		49,2X103,1X43,6		820-400-2480	3	0,000	
40	0750.117.009	TAROLLBEARING	1		00.00.0000		49,2X103,1X43,6		820-400-2480	3	0,000	
50	---	RETAINING RING	1		00.00.0000		S= 2,40- 3,00(ABSTUFUNG:0,05MM)			3	0,000	
---	0630.531.065	RETAINING RING	1		00.00.0000		50X3		VOE12743111	5	16	
---	0630.501.111	RETAINING RING	1		00.00.0000		50X2,95			5	0,000	
---	0630.501.112	RETAINING RING	1		00.00.0000		50X2,9		0002640551	5	0,000	
---	0630.501.113	RETAINING RING	1		00.00.0000		50X2,85			5	0,000	
---	0630.501.114	RETAINING RING	1		00.00.0000		50X2,8		5004853	5	0,000	
---	0630.501.115	RETAINING RING	1		00.00.0000		50X2,75			5	0,000	
---	0630.501.116	RETAINING RING	1		00.00.0000		50X2,7		5004854	5	0,000	
---	0630.501.117	RETAINING RING	1		00.00.0000		50X2,65			5	0,000	
---	0630.501.118	RETAINING RING	1		00.00.0000		50X2,6		0002641251	5	0,000	
---	0630.501.160	RETAINING RING	1		00.00.0000		50X2,55			5	0,000	
---	0630.531.064	RETAINING RING	1		00.00.0000		50X2,5		1663657	5	0,100	
---	0630.501.159	RETAINING RING	1		00.00.0000		50X2,45			5	0,000	
---	0630.501.148	RETAINING RING	1		00.00.0000		50X2,4		0002641051	5	0,000	
60	1315.303.004	HELICAL GEAR	1		00.00.0000					5	0,000	
70	1315.303.064	HELICAL GEAR	1		00.00.0000		KON 1			5	0,000	
80	1315.303.050	HELICAL GEAR	1		00.00.0000		ENTHALT.IN 1315 303 015(2)			5	0,000	
200	1315.303.060	GASKET	1	C0100534 9C10	00.00.0000	00.00.0000				5	0,000	
220	---	PUMP HOUSING	1		00.00.0000		GD*GSL5			3	0,000	
---	1315.302.121	PUMP HOUSING	1		00.00.0000					5	0,000	
---	1315.302.117	PUMP HOUSING	1		00.00.0000					5	0,000	

VKF Incidence factor

OTK Optional technical kit

ID Identification (output code)

SP Supplier plant



Pos.	Material number	Name	VKF	Amend. no.	Amend. start	Prod. no.	Material feature / tech. info.	OTK	External material no.	ID	Weight	SP
240	1314.202.039	PUMP SHAFT	1		00.00.0000		KPL.		169-831-0020	3	0,000	
250	1315.303.027	ROTOR	1		00.00.0000				169-833-0010	5	0,000	
270	---	PUMP COVER	1		00.00.0000		GD*GSLs			3	0,000	
---	1315.302.120	PUMP COVER	1		00.00.0000					5	0,000	
---	1315.302.116	PUMP COVER	1		00.00.0000					5	0,000	
300	0636.015.684	HEXAGON BOLT	8	Z0000917 7510	01.01.2012	01.01.2012	M10X85			5	0,000	
310	0636.015.685	HEXAGON BOLT	3	Z0000917 7310	01.01.2012	01.01.2012	M10X35			5	0,000	
320	0636.102.270	HEXAGON BOLT	1	Z0000917 7410	25.07.2011	25.07.2011	M10X60			5	0,000	
330	0636.015.685	HEXAGON BOLT	2	Z0000917 7310	01.01.2012	01.01.2012	M10X35			5	0,000	

VKF Incidence factor

OTK Optional technical kit

ID Identification (output code)

SP Supplier plant



Pos.	Material number	Name	VKF	Amend. no.	Amend. start	Prod. no.	Material feature / tech. info.	OTK	External material no.	ID	Weight	SP
10	1315.304.131	MAIN SHAFT	1		00.00.0000					5	0,000	
40	0735.321.087	NEEDLE CAGE	1		00.00.0000		92,0X100,0X53,0		8 8103 0	5	0,000	
50	1315.304.025	HELICAL GEAR	1		00.00.0000		2G/Z38 IN 1315 304 033(1)			5	0,000	
90	1315.204.006	SYNCHRONIZER	1		00.00.0000		KPL.1+2G*DK			3	0,000	
/110	1312.304.106	CLUTCH DISC	1		00.00.0000					5	0,000	
/120	1268.304.424	INNER RING	1		00.00.0000				820-400-2500	5	0,000	
/130	1268.304.494	INTERMRING	1		00.00.0000		ENTHALT.IN 6002 306 153(0)		820-400-2510	5	0,000	
/140	1268.304.525	OUTER RING	1		00.00.0000		ENTHALT.IN 1310 304 095(1)		133-441-1590	5	0,000	
/150	1312.304.158	SYNCHROBODY	1		00.00.0000		ZF-D171/164			5	0,000	
/160	1312.304.159	COUPLING ELEMENT	3	C0100689 3A10	00.00.0000	00.00.0000				5	0,030	
/170	1310.304.175	SLIDING SLEEVE	1	C0100731 7F10	00.00.0000	00.00.0000				5	0,000	
/180	0732.040.409	COMPRSPRING	3		00.00.0000					5	0,002	
/190	1297.304.436	PRESSURE PIECE	3		00.00.0000					5	0,004	
/200	1268.304.525	OUTER RING	1		00.00.0000		ENTHALT.IN 1310 304 095(1)		133-441-1590	5	0,000	
/210	1268.304.494	INTERMRING	1		00.00.0000		ENTHALT.IN 6002 306 153(0)		820-400-2510	5	0,000	
/220	1268.304.424	INNER RING	1		00.00.0000				820-400-2500	5	0,000	
/230	1312.304.106	CLUTCH DISC	1		00.00.0000					5	0,000	
140	1313.304.038	BUSH	1		00.00.0000		ENTHALT.IN 1312 304 007(2)			5	0,000	
150	0750.115.325	NEEDLE CAGE	1		00.00.0000		96,0X104,0X55,0		8 8106 0	3	0,000	
160	1315.304.004	HELICAL GEAR	1		00.00.0000		1G/Z47 IN 1315 304 020(1)			5	0,000	
180	1315.304.018	CLUTCH BODY	1		00.00.0000		RG			5	0,000	
200	1315.304.132	BUSH	1		00.00.0000		A=41,00 IN 1312 304 010(2)			5	0,000	
210	0750.115.324	NEEDLE CAGE	1		00.00.0000		90,0X98,0X41,0			3	0,000	
220	1315.304.006	HELICAL GEAR	1		00.00.0000		RG/Z44 IN 1315 304 019(0)			5	0,000	
260	0750.117.677	TAROLLBEARING	1		00.00.0000		80,0X130,0X36,0		8 8346 0	3	0,000	
270	---	RETAINING RING	1		00.00.0000		S= 2,20- 3,65(ABSTUFUNG:0,06MM)			3	0,000	
---	0630.501.316	RETAINING RING	1		00.00.0000		80X3,5		820-400-2580	5	0,000	
---	0630.501.336	RETAINING RING	1		00.00.0000		80X3,45		820-400-2581	5	0,000	

VKF Incidence factor

OTK Optional technical kit

ID Identification (output code)

SP Supplier plant



Pos.	Material number	Name	VKF	Amend. no.	Amend. start	Prod. no.	Material feature / tech. info.	OTK	External material no.	ID	Weight	SP
---	0630.501.315	RETAINING RING	1		00.00.0000		80X3,4		820-400-2582	5	0,000	
---	0630.501.335	RETAINING RING	1		00.00.0000		80X3,35		820-400-2583	5	0,000	
---	0630.501.314	RETAINING RING	1		00.00.0000		80X3,3		820-400-2584	5	0,000	
---	0630.501.334	RETAINING RING	1		00.00.0000		80X3,25		820-400-2585	5	0,000	
---	0630.501.313	RETAINING RING	1		00.00.0000		80X3,2		820-400-2586	5	0,000	
---	0630.501.333	RETAINING RING	1		00.00.0000		80X3,15		820-400-2587	5	0,000	
---	0630.501.312	RETAINING RING	1		00.00.0000		80X3,1		820-400-2588	5	0,000	
---	0630.501.337	RETAINING RING	1		00.00.0000		80X3,55		820-400-2589	5	0,000	
---	0630.501.338	RETAINING RING	1		00.00.0000		80X3,6		820-400-2590	5	0,000	
---	0630.501.339	RETAINING RING	1		00.00.0000		80X3,65		820-400-2591	5	0,000	
280	1315.332.073	PRESSURE DISC	1		00.00.0000					5	0,000	
300	1312.304.150	PIPE	1		00.00.0000				820-400-2610	5	0,000	
320	0735.321.087	NEEDLE CAGE	1		00.00.0000		92,0X100,0X53,0		8 8103 0	5	0,000	
330	1315.304.027	HELICAL GEAR	1		00.00.0000		3G/Z34 IN 1315 304 034(1)			5	0,000	
350	1316.304.190	CLUTCH BODY	1	Z0000698 1311	31.12.2011	31.12.2011	ZF-BK 144 O			5	0,000	
370	1356.204.006	SYNCHRONIZER	1	Z0000698 1311	31.12.2011	31.12.2011	KPL.3+4G*BK144 MOLYBDAEN*ANSCHL. INTEGR VERST*ECOSPLIT 3 +4			3	0,000	
/10	1356.304.019	SYNCHROBODY	1	Z0000698 1313	19.05.2010	19.05.2010				5	0,000	
/20	1356.304.023	SLIDING SLEEVE	1	Z0000698 1313	19.05.2010	19.05.2010	ZF-BK 144			5	0,000	
/30	1316.304.189	SYNCHRO RING	2	Z0000698 1313	19.05.2010	19.05.2010	ZF-BK 144		1832004	5	0,000	
/50	1297.304.436	PRESSURE PIECE	3	Z0000698 1313	19.05.2010	19.05.2010				5	0,004	
/60	0732.040.409	COMPRSPRING	3	Z0000698 1313	19.05.2010	19.05.2010				5	0,002	
390	1316.304.190	CLUTCH BODY	1	Z0000698 1311	31.12.2011	31.12.2011	ZF-BK 144 O			5	0,000	

VKF Incidence factor

OTK Optional technical kit

ID Identification (output code)

SP Supplier plant



Pos.	Material number	Name	VKF	Amend. no.	Amend. start	Prod. no.	Material feature / tech. info.	OTK	External material no.	ID	Weight	SP
410	0750.101.158	THRUST WASHER	2		00.00.0000					3	0,000	
420	0750.119.125	INNER RING	1		00.00.0000		67,0X77,0X54,1			3	0,000	
430	0750.115.534	ROLLER CAGE	2		00.00.0000		77,0X101,0X29,0			3	0,000	
440	1315.304.089	HELICAL GEAR	1		00.00.0000		ENTHALT.IN 1315 304 023(1)			5	0,000	
460	---	AXIAL WASHER	1		00.00.0000		S= 7,30- 8,00(ABSTUFUNG:0, 10MM)			3	0,000	
---	1315.304.048	AXIAL WASHER	1		00.00.0000		A=8,00 IN 1315 304 042(2)			5	0,000	
---	1315.304.047	AXIAL WASHER	1		00.00.0000		A=7,90 IN 1315 304 042(2)			5	0,000	
---	1315.304.046	AXIAL WASHER	1		00.00.0000		A=7,80 IN 1315 304 042(2)			5	0,000	
---	1315.304.045	AXIAL WASHER	1		00.00.0000		A=7,70 IN 1315 304 042(2)			5	0,000	
---	1315.304.044	AXIAL WASHER	1		00.00.0000		A=7,60 IN 1315 304 042(2)			5	0,000	
---	1315.304.043	AXIAL WASHER	1		00.00.0000		A=7,50 IN 1315 304 042(2)			5	0,000	
---	1315.304.085	AXIAL WASHER	1		00.00.0000		A=7,40 IN 1315 304 042(2)			5	0,000	
---	1315.304.086	AXIAL WASHER	1		00.00.0000		A=7,30 IN 1315 304 042(2)			5	0,000	
480	0750.117.232	TAROLLBEARING	1		00.00.0000		42,0X40,3		820-400-2650	3	0,000	
500	1312.204.040	SPLIT RING	1		00.00.0000		GESTANZT			3	0,000	
/10	---	SPLIT RING	2		00.00.0000		S= 4,60- 5,00(ABSTUFUNG:0, 10MM)			3	0,000	
---	0730.107.023	SPLIT RING	2		00.00.0000		A=5,00 IN 0730 106 207(2)		820-400-2660	5	0,000	
---	0730.107.022	SPLIT RING	2		00.00.0000		A=4,90 IN 0730 106 207(2)		820-400-2661	5	0,000	
---	0730.107.021	SPLIT RING	2		00.00.0000		A=4,80 IN 0730 106 207(2)		820-400-2662	5	0,000	
---	0730.107.020	SPLIT RING	2		00.00.0000		A=4,70 IN 0730 106 207(2)		820-400-2663	5	0,000	
---	0730.107.019	SPLIT RING	2		00.00.0000		A=4,60 IN 0730 106 207(2)		820-400-2664	5	0,000	
/20	0730.062.781	RETAINING RING	1		00.00.0000		ENTHALT.IN 0730 062 636(2)		820-400-2670	5	0,000	

VKF Incidence factor

OTK Optional technical kit

ID Identification (output code)

SP Supplier plant

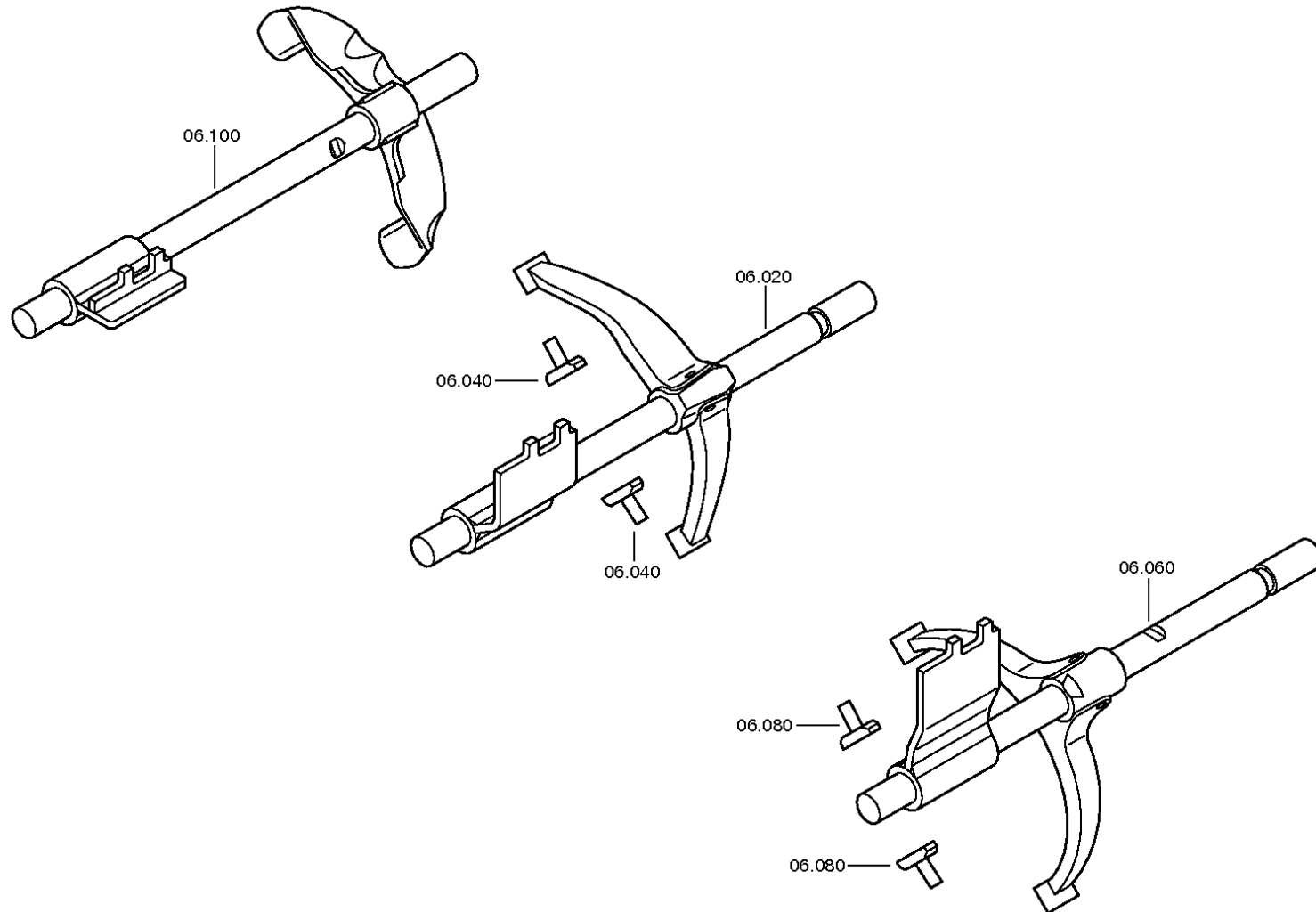

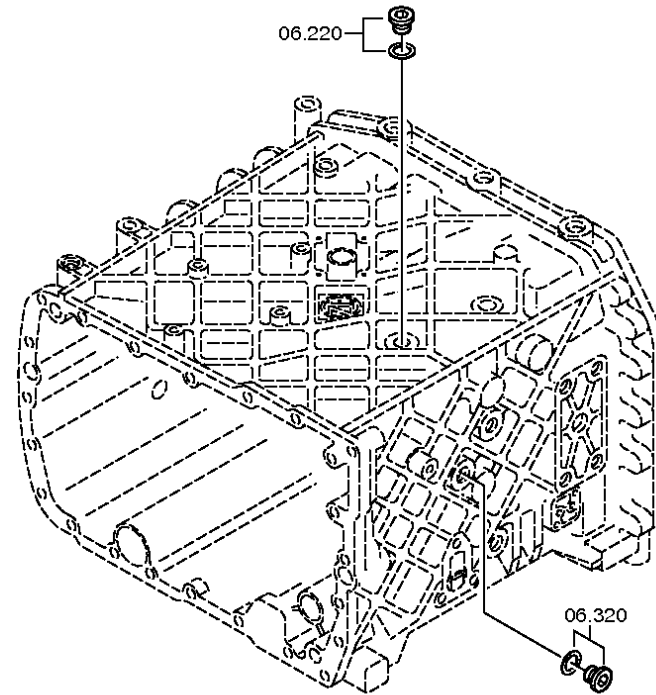

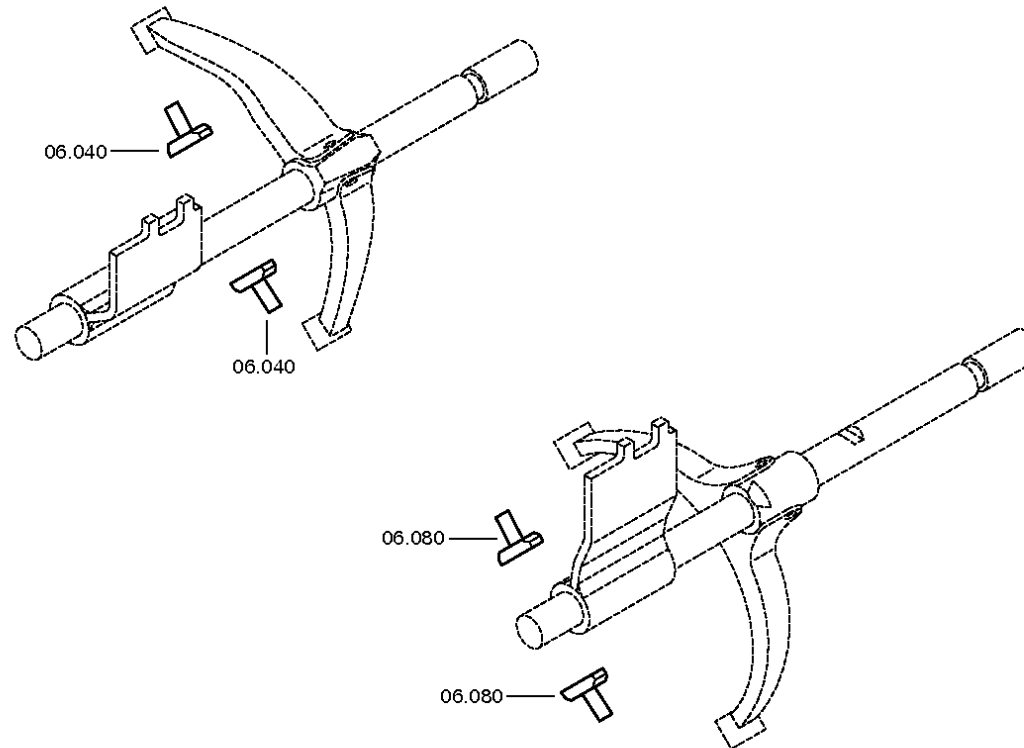



Pos.	Material number	Name	VKF	Amend. no.	Amend. start	Prod. no.	Material feature / tech. info.	OTK	External material no.	ID	Weight	SP
20	1315.206.076	GEAR SHIFT RAIL	1		00.00.0000		1+2GANG*KURZ*WI			3	0,000	
/10	1315.306.099	GEAR SHIFT RAIL	1		00.00.0000					5	0,000	
/20	1355.306.006	GEAR SHIFT FORK	1		00.00.0000		1/2G			5	0,000	
40	1316.306.015	SLIDING PAD	2		00.00.0000					5	0,000	
60	1315.206.079	GEAR SHIFT RAIL	1		00.00.0000		3+4GANG*KURZ*WI			3	0,000	
/10	1315.306.106	GEAR SHIFT RAIL	1		00.00.0000					5	0,000	
/20	1325.306.028	GEAR SHIFT FORK	1		00.00.0000		3/4G			5	0,000	
/50	0631.329.086	SLOTPIN	1		00.00.0000		8X40		0148103897	5	7,800	
/60	0631.329.057	SLOTPIN	1		00.00.0000		5X40			5	3,200	
80	1316.306.015	SLIDING PAD	2		00.00.0000					5	0,000	
100	1315.206.083	GEAR SHIFT RAIL	1		00.00.0000		R-GANG*KURZ*WI			3	0,000	
/10	1315.306.103	GEAR SHIFT RAIL	1		00.00.0000					5	0,000	
/20	1355.306.003	GEAR SHIFT FORK	1		00.00.0000		RG			5	0,000	
/50	0631.329.086	SLOTPIN	1		00.00.0000		8X40		0148103897	5	7,800	
/60	0631.329.057	SLOTPIN	1		00.00.0000		5X40			5	3,200	
220	---	SCREW PLUG	1	Z0001011 1513	01.01.2012	01.01.2012	35N.M*DICHTRING M18X1,5			3	0,000	
---	0636.100.791	SCREW PLUG	1	Z0001011 1521	15.11.2010	15.11.2010	M18X1,5			5	0,000	
---	0634.801.062	SEALING RING	1	Z0001011 1521	15.11.2010	15.11.2010	18X24			5	0,001	
320	---	SCREW PLUG	1	Z0001011 1513	01.01.2012	01.01.2012	35N.M*DICHTRING M18X1,5			3	0,000	
---	0636.100.791	SCREW PLUG	1	Z0001011 1521	15.11.2010	15.11.2010	M18X1,5			5	0,000	
---	0634.801.062	SEALING RING	1	Z0001011 1521	15.11.2010	15.11.2010	18X24			5	0,001	

VKF Incidence factor

OTK Optional technical kit

ID Identification (output code)

SP Supplier plant

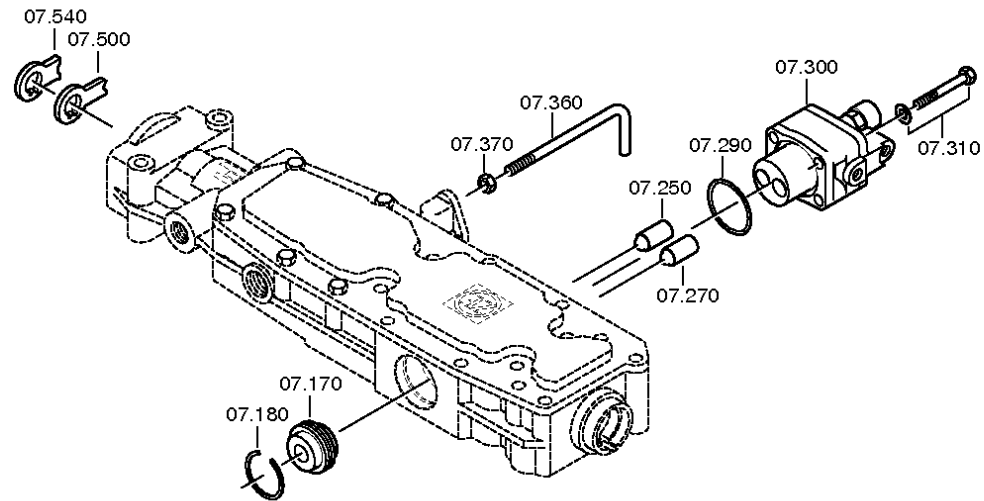

Material number: 1341.002.056
Plant: 068.07.09-1
GEAR SHIFT SHAFT

16 S 1825 TO /
GEAR SHIFT HOUSING

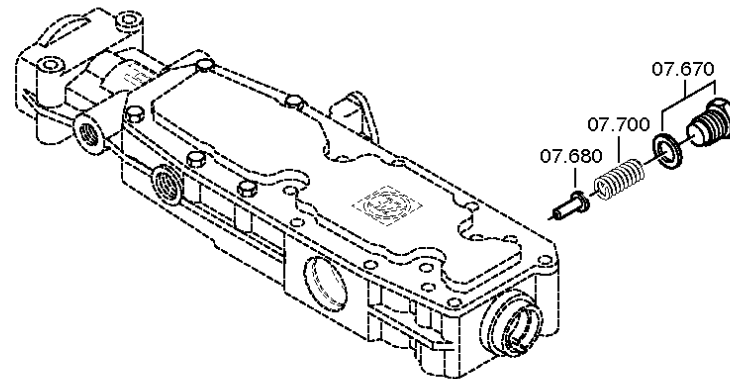

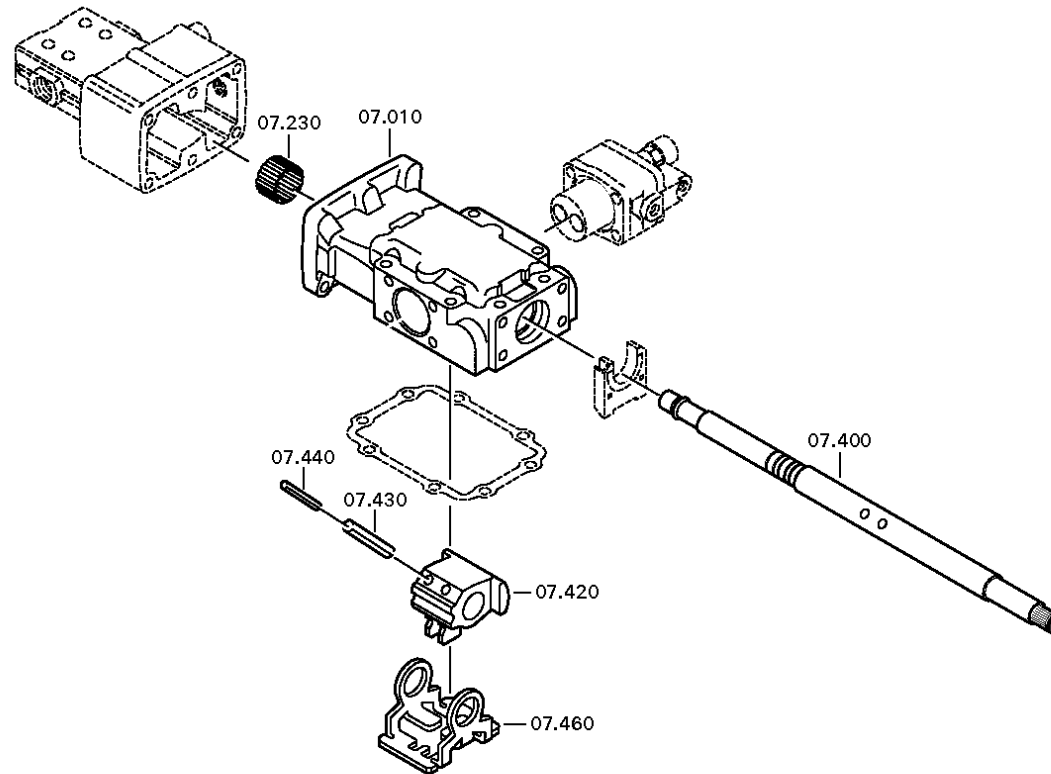

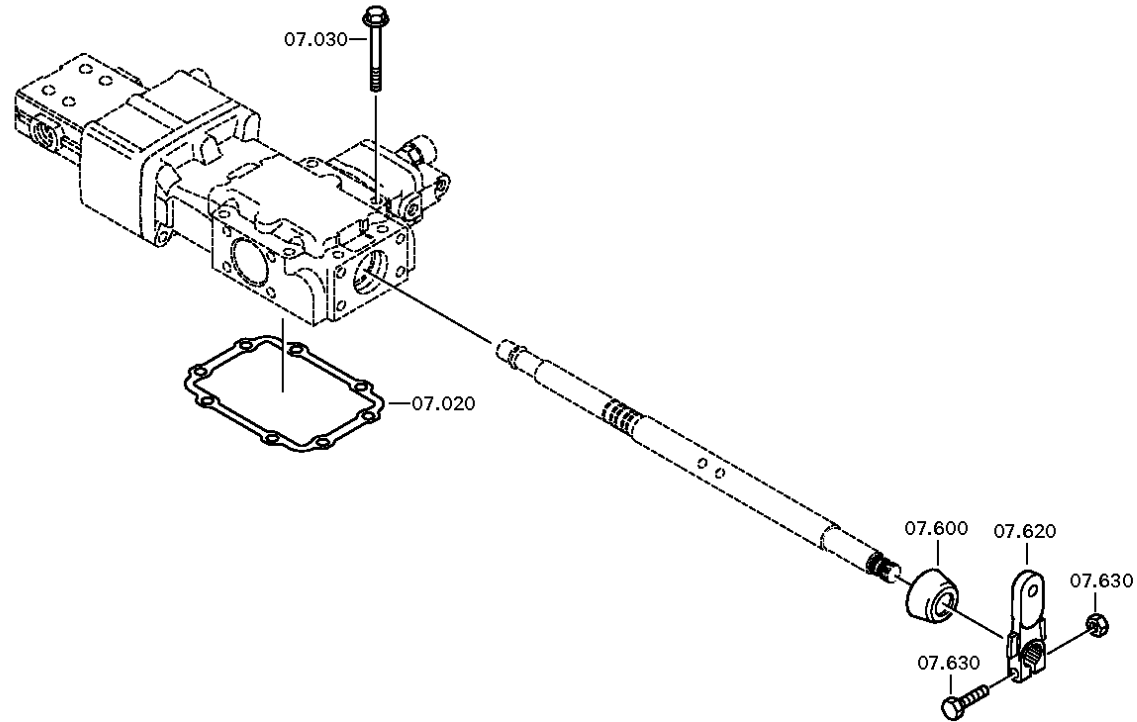



Pos.	Material number	Name	VKF	Amend. no.	Amend. start	Prod. no.	Material feature / tech. info.	OTK	External material no.	ID	Weight	SP
10	1315.307.123	GEAR SHIFT HOUSING	1		00.00.0000		ENTHALT.IN 1315 307 122(0)			5	0,000	
20	1315.307.013	GASKET	1		00.00.0000				133-138-1020	5	0,000	
30	0736.300.136	HEXAGON BOLT	8	Z0000919 5210	27.02.2012	27.02.2012	M8X75 M8X75			5	0,000	
170	0501.209.212	DETENT	1		00.00.0000		KPL.			5	0,000	
180	0630.532.130	V-RING	1		00.00.0000					5	0,000	
230	0635.303.053	NEEDLE SLEEVE	1		00.00.0000		25X32X20		35055200	5	120	
250	0501.209.188	BALL ROLLER	1		00.00.0000		KPL.		5 6102 0	5	0,000	
270	0501.209.188	BALL ROLLER	1		00.00.0000		KPL.		5 6102 0	5	0,000	
290	0634.313.505	O-RING	1		00.00.0000		42X3			5	0,000	
300	6038.202.043	CUT-OFF VALVE	1	C0100214 4C10	00.00.0000	00.00.0000	KPL.H-H*ZULUFTDROSSEL 1,55		5 6065 0	3	0,000	
310	---	HEXAGON BOLT	4	Z0000705 4112	31.12.2011	31.12.2011	M8X65			3	0,000	
---	0636.100.519	HEXAGON BOLT	4	Z0000705 4110	04.08.2010	04.08.2010	M8X65			5	0,000	
---	0630.100.295	WASHER	4	Z0000715 8414	30.11.2011	30.11.2011				5	0,000	
360	1316.307.431	BRACKET	1	Z0000944 0410	31.12.2011	31.12.2011				5	0,000	
370	0637.006.280	HEXAGON NUT	1	Z0000728 2715	01.01.2012	01.01.2012	M8			5	0,000	
400	1315.307.094	GEAR SHIFT SHAFT	1		00.00.0000		ENTHALT.IN 1315 307 157(1)			5	0,000	
420	---	DRIVER	1		00.00.0000		W I			3	0,000	
---	1315.307.092	DRIVER	1		00.00.0000					5	0,000	
430	0631.329.101	SLOTPIN	2		00.00.0000		10X45			5	15	
440	0631.329.073	SLOTPIN	2		00.00.0000		6X45			5	0,000	
460	1315.307.308	LOCKING PIECE	1		00.00.0000					5	0,000	
500	1315.307.304	DETENT SHEET	1		00.00.0000					5	0,000	
540	1315.307.120	DETENT	1		00.00.0000					5	0,000	

VKF Incidence factor

OTK Optional technical kit

ID Identification (output code)

SP Supplier plant



Pos.	Material number	Name	VKF	Amend. no.	Amend. start	Prod. no.	Material feature / tech. info.	OTK	External material no.	ID	Weight	SP
600	---	PROTECTING CAP	1	Z0000917 4510	31.12.2011	31.12.2011				3	0,000	
620	6005.300.590	GEAR SHIFT LEVER	1		00.00.0000		U413 IN 6005 300 601(1)			5	0,000	
630	---	BOLT+NUT	1	Z0000789 1713	01.01.2012	01.01.2012	M10X40			3	0,000	
---	0636.100.789	HEXAGON BOLT	1	Z0000789 1711	13.12.2010	13.12.2010	M10X40			5	0,000	
---	0637.100.419	HEXAGON NUT	1	Z0000789 2710	01.03.2012	01.03.2012	M10			5	0,000	
670	---	SCREW	1	Z0001014 6310	31.12.2011	31.12.2011	M22X1,5			3	0,000	
---	1315.307.736	SCREW	1	Z0001014 6312	19.01.2011	19.01.2011	M22X1,5			5	0,000	
---	0730.009.515	SEALING RING	1	Z0001014 6312	19.01.2011	19.01.2011	A22X27			5	0,000	
680	1315.307.190	BOLT	1		00.00.0000		ENTHALT.IN 1250 307 589(2)			5	0,000	
700	0732.041.500	COMPRSPRING	1		00.00.0000					5	0,000	

VKF Incidence factor

OTK Optional technical kit

ID Identification (output code)

SP Supplier plant

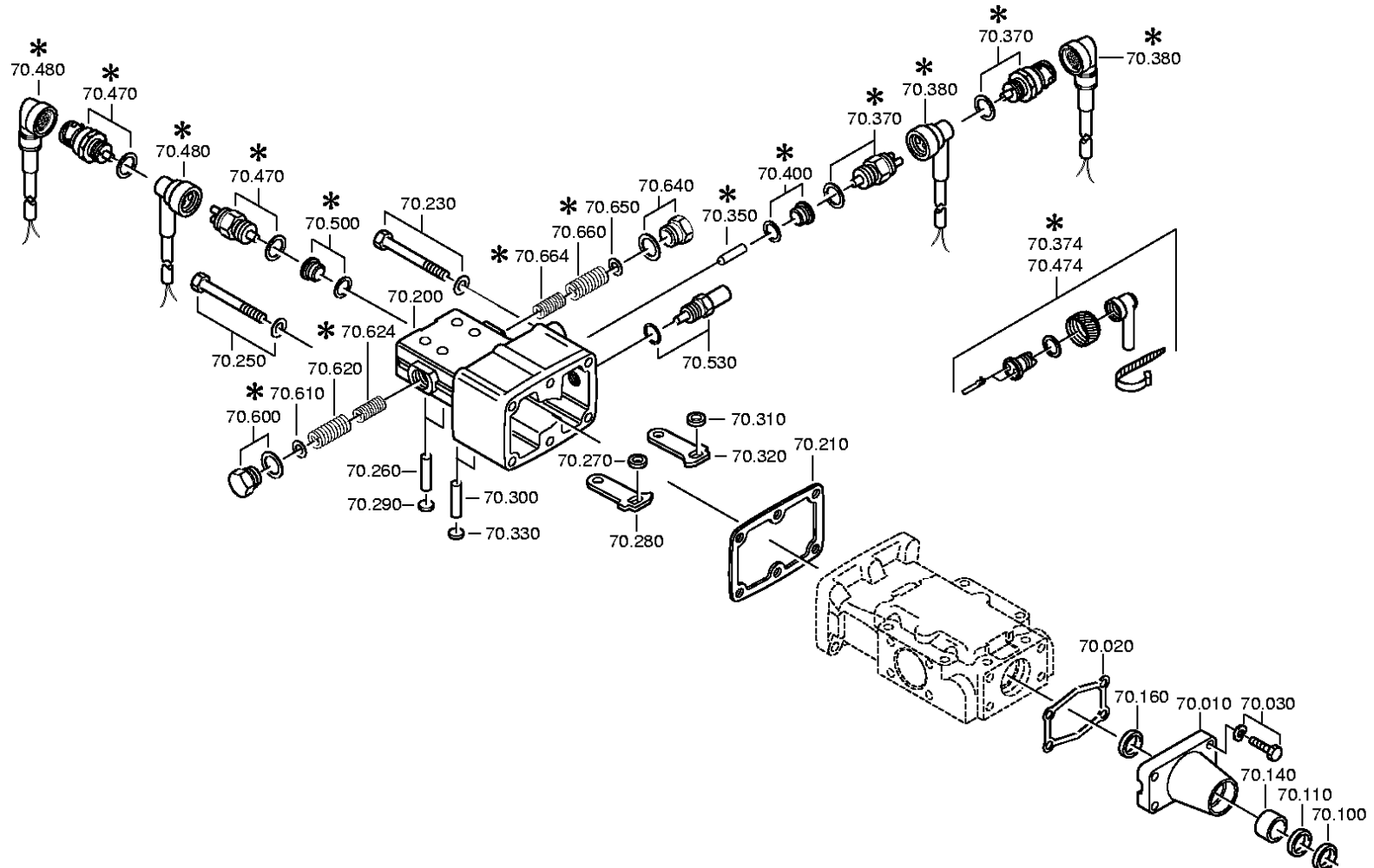

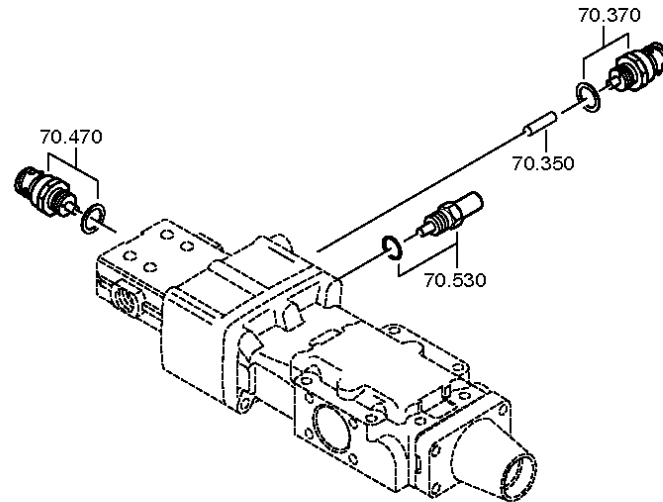

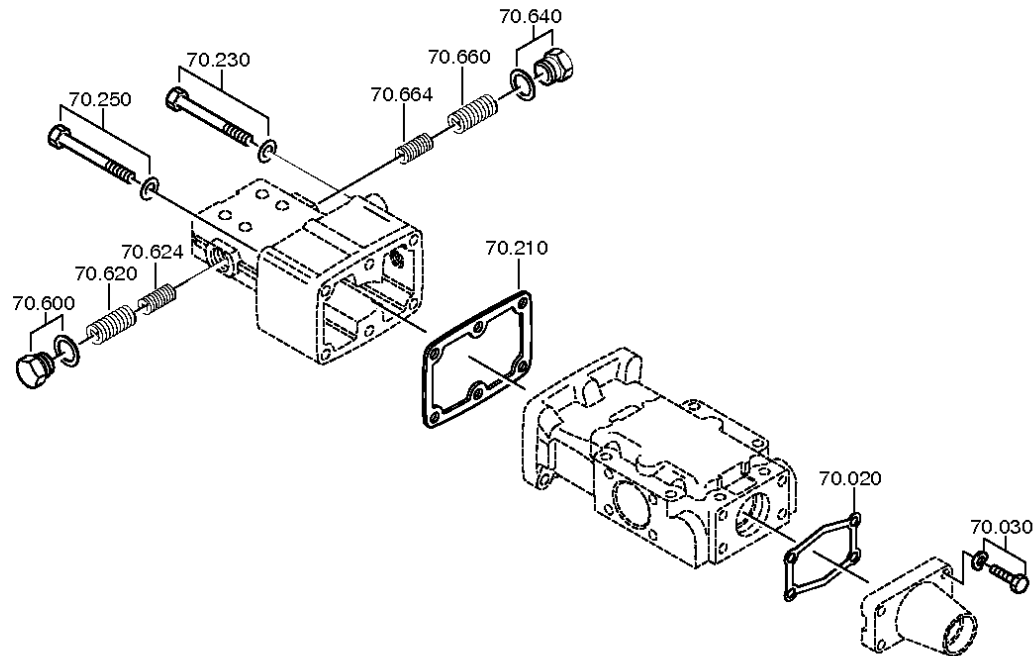

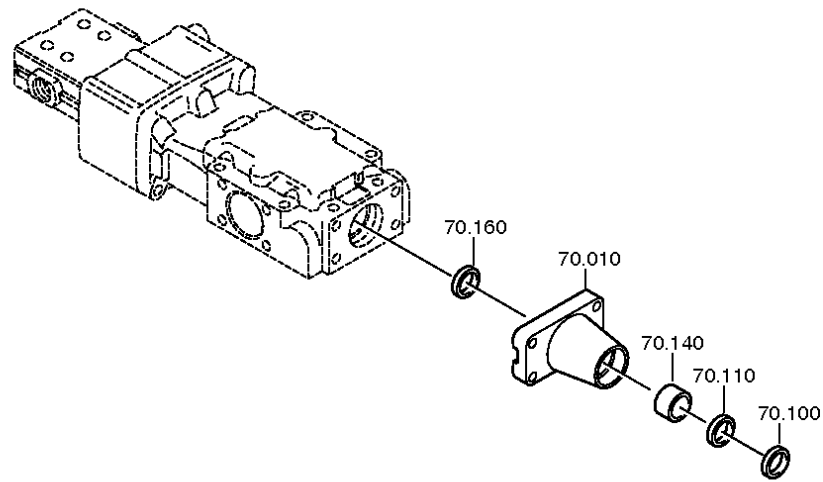



Pos.	Material number	Name	VKF	Amend. no.	Amend. start	Prod. no.	Material feature / tech. info.	OTK	External material no.	ID	Weight	SP
10	1304.307.425	GEAR SHIFT COVER	1		00.00.0000					5	0,000	
20	0501.318.308	GASKET	1		00.00.0000					5	0,000	
30	---	HEXAGON BOLT	4	Z0000789 1312	01.01.2012	01.01.2012	M8X30			3	0,000	
---	0636.100.797	HEXAGON BOLT	4	Z0000789 1310	07.09.2010	07.09.2010	M8X30			5	0,000	
---	0630.100.295	WASHER	4	Z0000715 8414	30.11.2011	30.11.2011				5	0,000	
100	0634.307.367	SCRAPER	1		00.00.0000				2150035300	5	0,009	
110	---	SHAFT SEAL	1	C0100893 3B10	00.00.0000	00.00.0000	25X35X7			3	0,000	
---	0734.300.196	SHAFT SEAL	1		00.00.0000		25X35X7 FA.CFW			5	0,000	
140	0730.260.330	BEARING BUSH	1		00.00.0000		A=20,00 IN 0730 260 546(2)		5006867	5	0,000	
160	0634.300.020	SHAFT SEAL	1		00.00.0000		25X32X5		5006866	5	0,000	
200	1315.307.140	HOUSING	1		00.00.0000		GASSEN-SPERRE			5	0,000	
210	1315.307.012	GASKET	1		00.00.0000					5	0,000	
230	---	HEXAGON BOLT	3	Z0000706 9014	31.12.2011	31.12.2011	M8X85			3	0,000	
---	0636.011.764	HEXAGON BOLT	3	Z0000706 9013	09.07.2010	09.07.2010	M8X85			5	0,000	
---	0630.100.295	WASHER	3	Z0000715 8414	30.11.2011	30.11.2011				5	0,000	
250	---	HEXAGON BOLT	3	Z0000706 9014	31.12.2011	31.12.2011	M8X85			3	0,000	
---	0636.011.764	HEXAGON BOLT	3	Z0000706 9013	09.07.2010	09.07.2010	M8X85			5	0,000	
---	0630.100.295	WASHER	3	Z0000715 8414	30.11.2011	30.11.2011				5	0,000	
260	0631.306.226	CYLINDRICAL PIN	2		00.00.0000		6X32			5	0,000	
270	0730.006.347	RING	1		00.00.0000				SA 8320-05460	5	5	
280	1304.307.019	DETENT LEVER	1		00.00.0000					5	0,000	
290	---	SEALING CAP	2		00.00.0000		14			3	0,000	

VKF Incidence factor

OTK Optional technical kit

ID Identification (output code)

SP Supplier plant



Pos.	Material number	Name	VKF	Amend. no.	Amend. start	Prod. no.	Material feature / tech. info.	OTK	External material no.	ID	Weight	SP
---	0630.361.032	SEALING CAP	2		00.00.0000					5	2,100	
300	0631.306.226	CYLINDRICAL PIN	2		00.00.0000		6X32			5	0,000	
310	0730.006.347	RING	1		00.00.0000				SA 8320-05460	5	5	
320	1304.307.019	DETENT LEVER	1		00.00.0000					5	0,000	
330	---	SEALING CAP	2		00.00.0000		14			3	0,000	
---	0630.361.032	SEALING CAP	2		00.00.0000					5	2,100	
350	0731.208.230	PIN	1		00.00.0000		A=30,0			5	0,000	
370	---	SWITCH	1	Z0000428 7211	20.05.2010	20.05.2010	OEFF*45N.M*DICHTRING* BAJONETT*SCHUTZKAPPE			3	0,000	
---	0501.216.474	SWITCH	1		00.00.0000					5	0,050	
---	0634.801.062	SEALING RING	1		00.00.0000		18X24			5	0,001	
---	0700.300.427	PROTECTING CAP	1		00.00.0000					5	0,005	
470	---	SWITCH	1	Z0000428 7211	20.05.2010	20.05.2010	SCHL*45N.M*DICHTRING* BAJONETT*SCHUTZKAPPE			3	0,000	
---	0501.210.058	SWITCH	1		00.00.0000		KPL.		1864900531	5	0,000	
---	0634.801.062	SEALING RING	1		00.00.0000		18X24			5	0,001	
---	0700.300.427	PROTECTING CAP	1		00.00.0000					5	0,005	
530	---	DETENT PLUNGER	1		00.00.0000		168N*50N.M*WL			3	0,000	
---	1324.207.004	DETENT PLUNGER	1	Z0000953 1710	01.12.2012	01.12.2012	KPL. *168 N			3	0,000	
---	0630.000.072	SHIM RING	1		00.00.0000		16X22X1		1000000168	5	0,010	
600	---	SCREW	1	Z0001014 6310	31.12.2011	31.12.2011	M22X1,5			3	0,000	
---	1315.307.736	SCREW	1	Z0001014 6312	19.01.2011	19.01.2011	M22X1,5			5	0,000	
---	0730.009.515	SEALING RING	1	Z0001014 6312	19.01.2011	19.01.2011	A22X27			5	0,000	
620	0732.040.985	COMPRSPRING	1		00.00.0000				5006738	5	0,000	
624	0732.040.984	COMPRSPRING	1		00.00.0000				0732 040 984	5	0,000	
640	---	SCREW	1	Z0001014 6310	31.12.2011	31.12.2011	M22X1,5			3	0,000	

VKF Incidence factor

OTK Optional technical kit

ID Identification (output code)

SP Supplier plant



Pos.	Material number	Name	VKF	Amend. no.	Amend. start	Prod. no.	Material feature / tech. info.	OTK	External material no.	ID	Weight	SP
---	1315.307.736	SCREW	1	Z0001014 6312	19.01.2011	19.01.2011	M22X1,5			5	0,000	
---	0730.009.515	SEALING RING	1	Z0001014 6312	19.01.2011	19.01.2011	A22X27			5	0,000	
660	0732.040.985	COMPRSPRING	1		00.00.0000				5006738	5	0,000	
664	0732.040.984	COMPRSPRING	1		00.00.0000				0732 040 984	5	0,000	

VKF Incidence factor

OTK Optional technical kit

ID Identification (output code)

SP Supplier plant

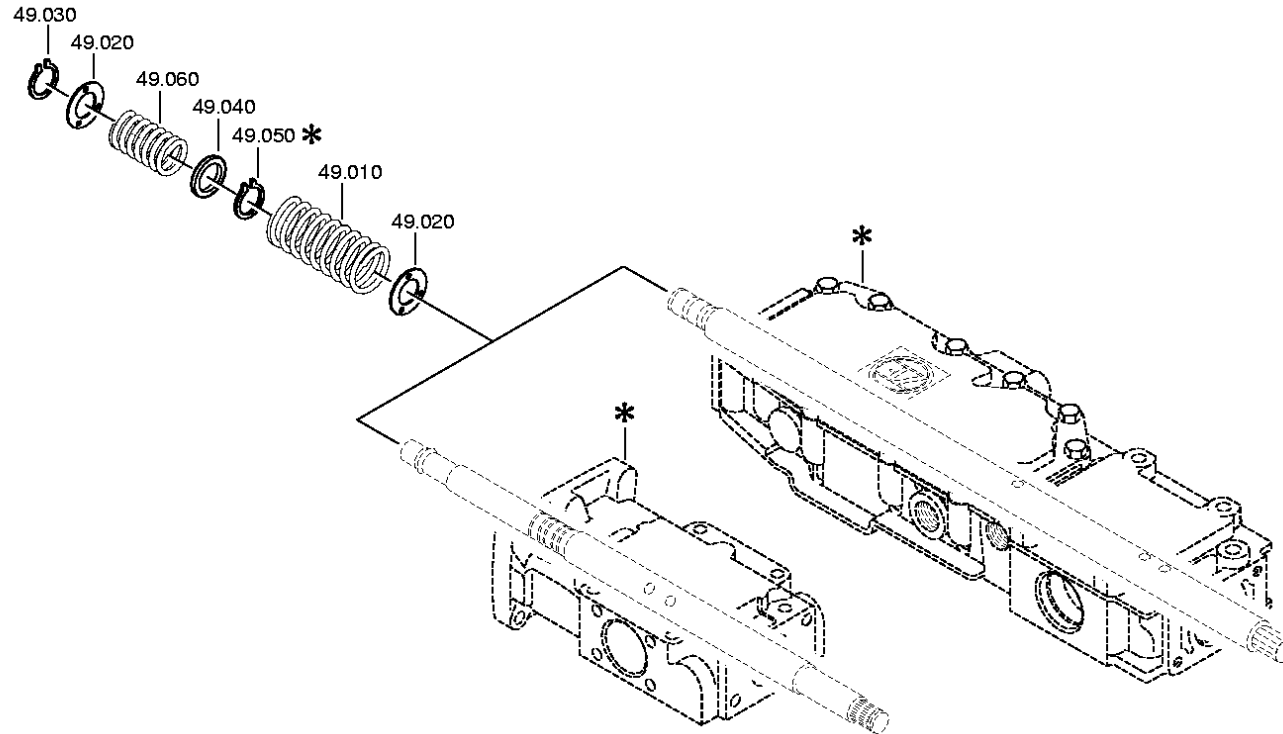



Pos.	Material number	Name	VKF	Amend. no.	Amend. start	Prod. no.	Material feature / tech. info.	OTK	External material no.	ID	Weight	SP
10	0732.042.684	COMPRSPRING	1		00.00.0000					5	0,000	
20	0730.301.376	WASHER	2	Z0000891 7410	31.12.2011	31.12.2011				5	0,000	
30	0630.532.138	V-RING	1		00.00.0000				5004143	5	0,000	
40	0730.301.374	WASHER	1	Z0000891 7310	01.01.2012	01.01.2012	A=2,00 A=2,00			5	0,000	
50	0630.532.138	V-RING	1		00.00.0000				5004143	5	0,000	
60	0732.040.904	COMPRSPRING	1		00.00.0000					5	0,000	

VKF Incidence factor

OTK Optional technical kit

ID Identification (output code)

SP Supplier plant

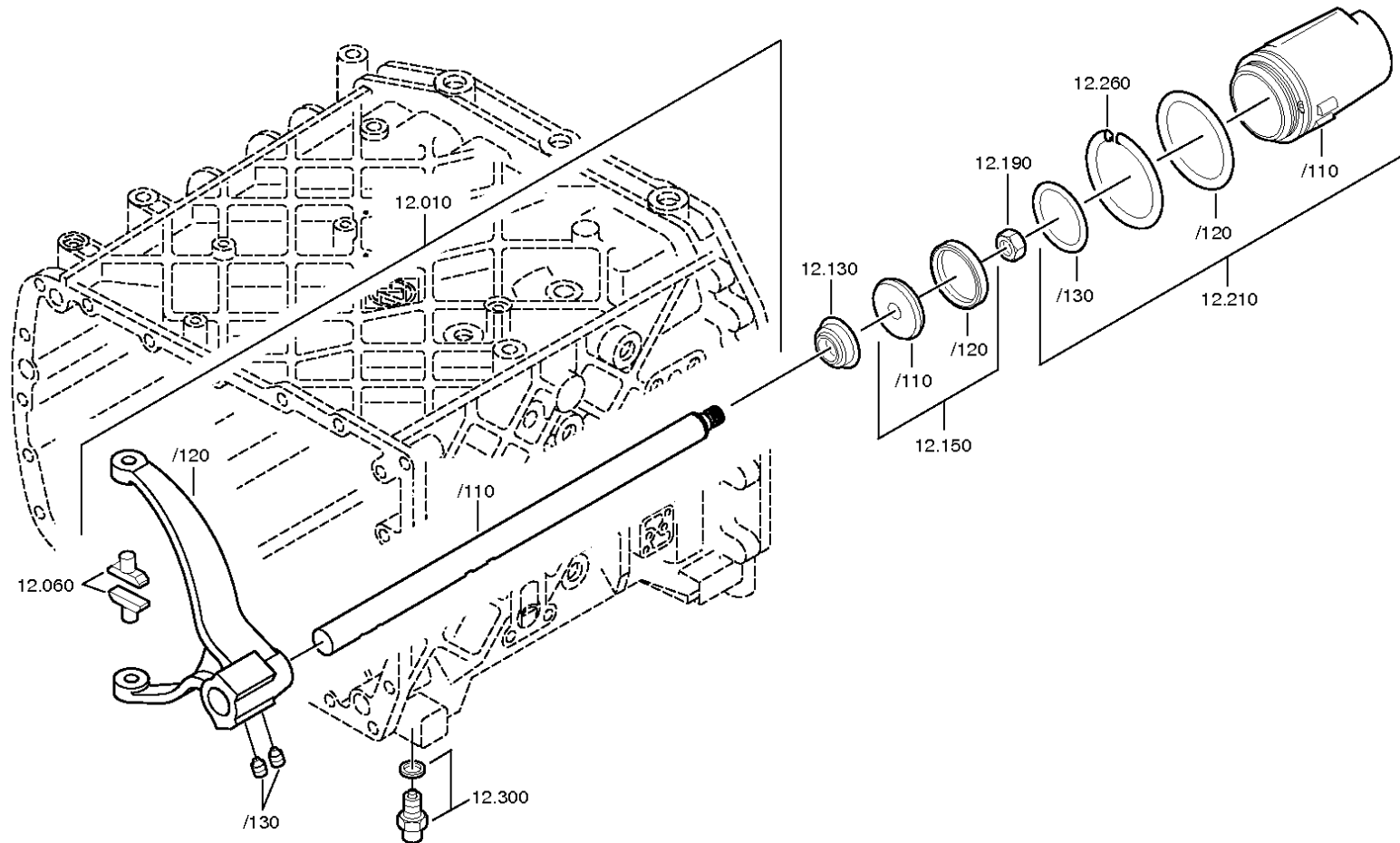

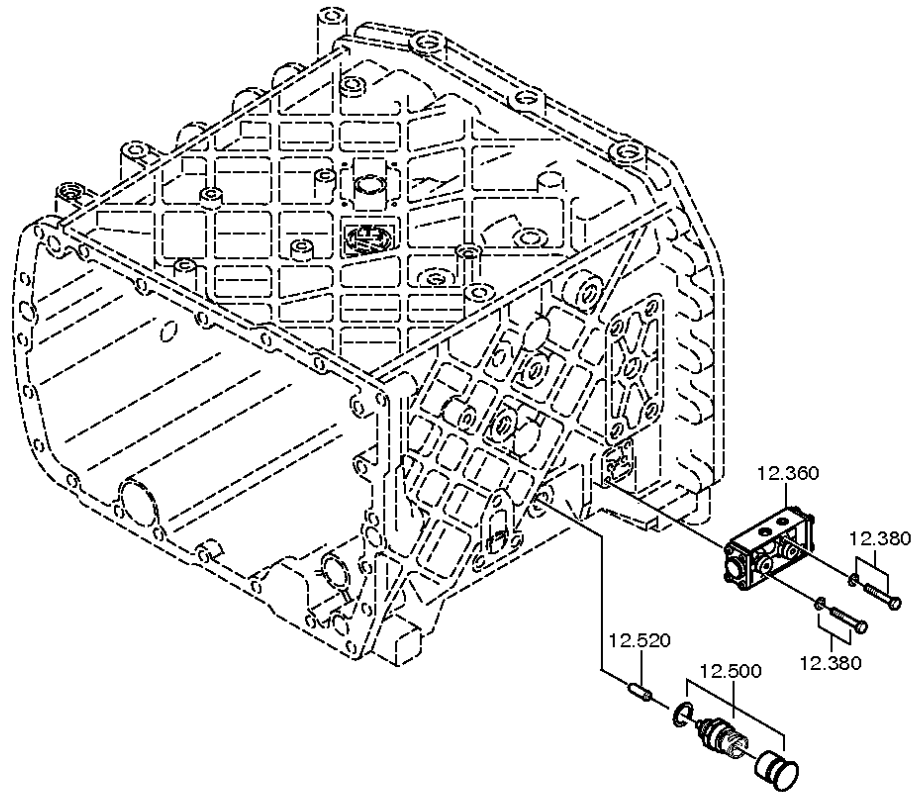



Pos.	Material number	Name	VKF	Amend. no.	Amend. start	Prod. no.	Material feature / tech. info.	OTK	External material no.	ID	Weight	SP
10	1315.212.013	GEAR SHIFT RAIL	1		00.00.0000		KPL.GV.LAG.GEH.1			3	0,000	
/110	1315.312.073	GEAR SHIFT RAIL	1		00.00.0000					5	0,000	
/120	1315.312.074	GEAR SHIFT FORK	1		00.00.0000		GV ECO 3			5	0,000	
/130	---	SET SCREW	2		00.00.0000		M12X1			3	0,000	
---	1315.312.047	SET SCREW	2		00.00.0000				42172912	5	0,000	
60	1316.306.015	SLIDING PAD	2		00.00.0000					5	0,000	
130	0750.112.131	FLANGE PACKING	1	Z0000358 8010	31.12.2010	31.12.2010	25X40X15		820-400-2880	3	0,000	
150	1315.212.008	PISTON	1		00.00.0000		KPL.		1831971	3	0,000	
/110	---	PISTON	1		00.00.0000		GV SINTER/STAHL			3	0,000	
---	1315.312.020	PISTON	1		00.00.0000		GV			5	0,000	
---	1315.312.003	PISTON	1		00.00.0000		GV			5	0,000	
/120	0750.112.177	DOUBLE U-PACKING	1		00.00.0000		55X63X9,4		172-255-1720	3	0,000	
190	0737.300.037	LOCKING NUT	1	Z0000892 9010	31.12.2011	31.12.2011	MS16X1,5			5	0,000	
210	1315.212.010	CYLINDER	1		00.00.0000		KPL.			3	0,000	
/110	1315.312.048	CYLINDER	1		00.00.0000		ENTHALT.IN 1315 312 033(1)			5	0,000	
/120	0634.313.018	O-RING	1		00.00.0000		82X3			5	0,000	
/130	0634.313.320	O-RING	1		00.00.0000		67X3		820-400-2910	5	0,000	
260	1315.312.034	SPRING	1		00.00.0000					5	0,000	
300	---	DETENT PLUNGER	1		00.00.0000		235N*50N.M			3	0,000	
---	1324.207.033	DETENT PLUNGER	1		00.00.0000		KPL. *235 N			3	0,000	
---	0730.008.604	SEALING RING	1	C0100986 0C10	00.00.0000	00.00.0000				5	0,000	
360	0501.215.359	5/2 WAY VALVE	1	C0100400 3F10	00.00.0000	00.00.0000	KPL.SG			5	0,000	
/20	0634.314.020	O-RING	1		00.00.0000		8X2			5	0,000	
/22	0634.314.020	O-RING	1		00.00.0000		8X2			5	0,000	
380	---	HEXAGON BOLT	2		00.00.0000		M6X40			3	0,000	
---	0636.010.740	HEXAGON BOLT	2		00.00.0000		M6X40			5	0,000	

VKF Incidence factor

OTK Optional technical kit

ID Identification (output code)

SP Supplier plant



Pos.	Material number	Name	VKF	Amend. no.	Amend. start	Prod. no.	Material feature / tech. info.	OTK	External material no.	ID	Weight	SP
---	0630.001.139	WASHER	2	Z0000716 4311	03.01.2012	03.01.2012				5	0,000	
500	---	SWITCH	1	Z0000428 7211	20.05.2010	20.05.2010	OEFF*45N.M*DICHTRING* BAJONETT*SCHUTZKAPPE			3	0,000	
---	0501.216.474	SWITCH	1		00.00.0000					5	0,050	
---	0634.801.062	SEALING RING	1		00.00.0000		18X24			5	0,001	
---	0700.300.427	PROTECTING CAP	1		00.00.0000					5	0,005	
520	1295.212.006	PIN	1		00.00.0000		KPL.			3	0,000	

VKF Incidence factor

OTK Optional technical kit

ID Identification (output code)

SP Supplier plant

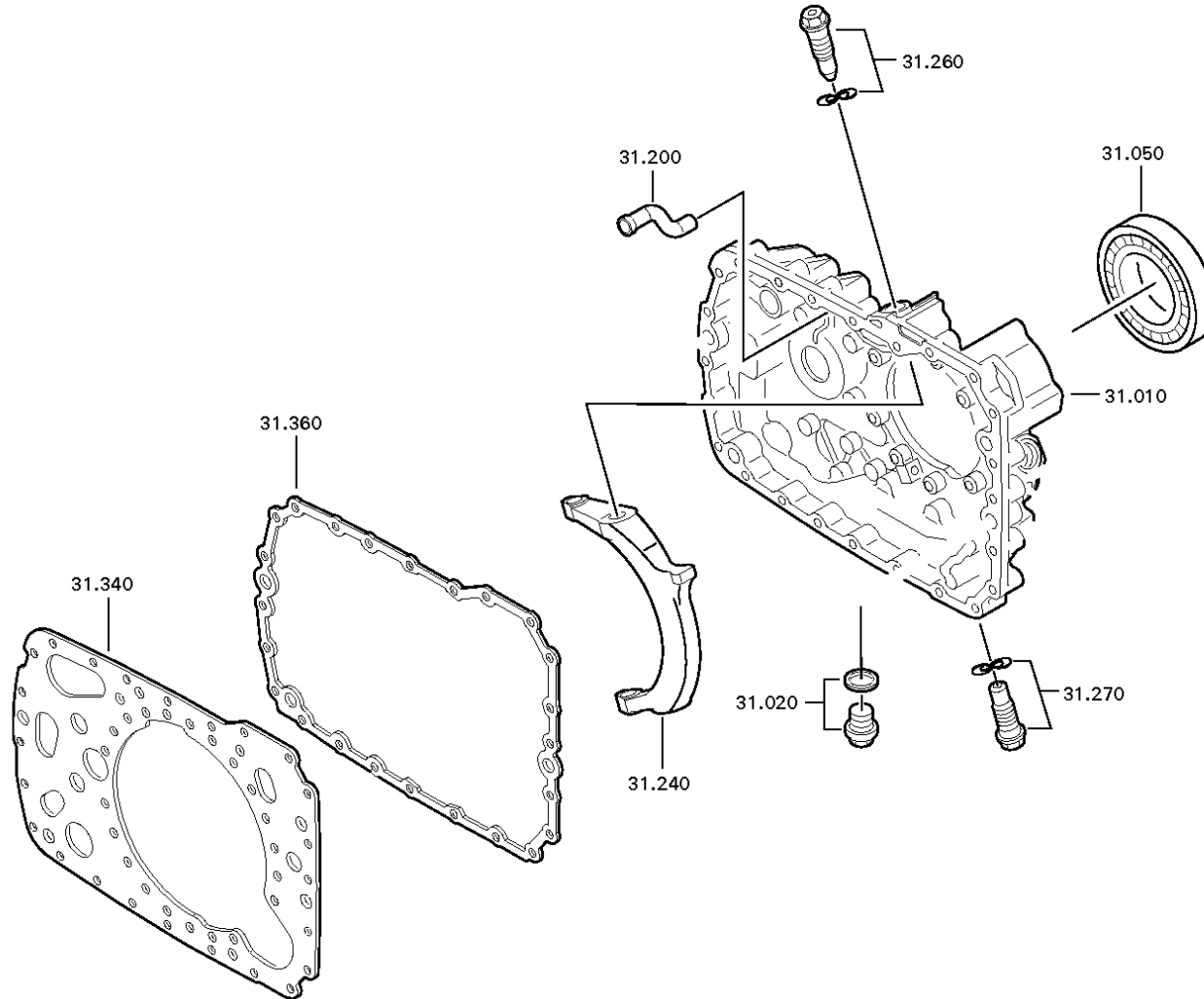

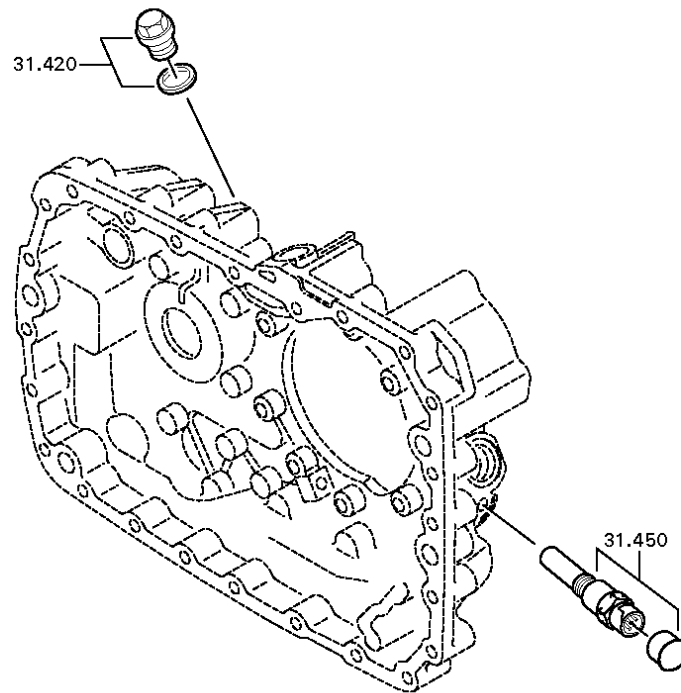

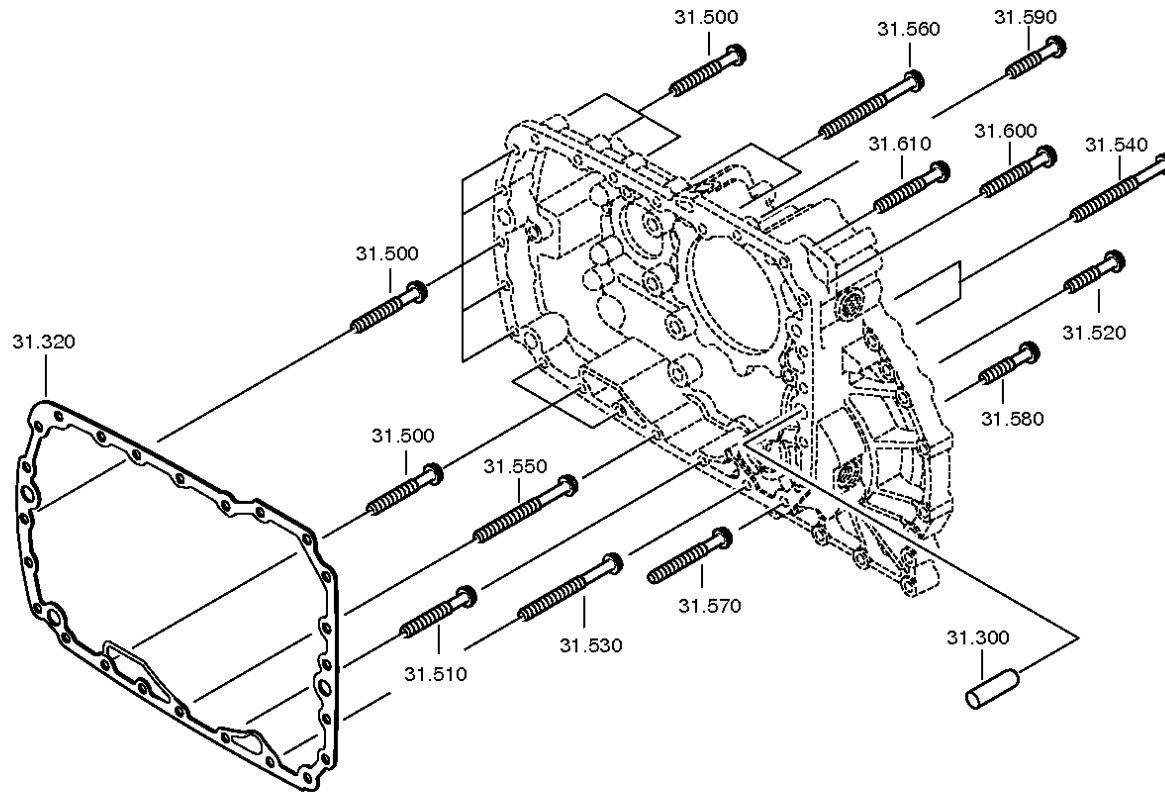



Pos.	Material number	Name	VKF	Amend. no.	Amend. start	Prod. no.	Material feature / tech. info.	OTK	External material no.	ID	Weight	SP
10	1315.301.224	HOUSING	1		00.00.0000		ENTHALT.IN 1315 301 222(0)			5	0,000	
20	---	SCREW PLUG	1	Z0001011 2111	31.12.2011	31.12.2011	60N.M*DICHTRING M24X1,5			3	0,000	
---	0636.304.088	SCREW PLUG	1	Z0001011 2110	24.11.2010	24.11.2010	M24X1,5			5	0,000	
---	0730.008.637	SEALING RING	1	Z0001011 2110	24.11.2010	24.11.2010	A24X29			5	0,000	
50	0750.116.394	BALL BEARING	1	C0100721 4E10	00.00.0000	00.00.0000			5 8092 0	3	0,000	
200	1296.301.008	SPRAY TUBE	1		00.00.0000				133-881-0130	5	0,000	
240	1315.334.039	GEAR SHIFT FORK	1		00.00.0000					5	0,000	
260	---	ARTICULATION BOLT	1	Z0000407 5611	05.05.2011	05.05.2011	O.SCHEIBE M24X1,5 SK6			3	0,000	
---	1315.334.074	ARTICULATION BOLT	1	Z0000407 5610	01.07.2011	01.07.2011				5	0,000	
270	---	ARTICULATION BOLT	1	Z0000407 5611	05.05.2011	05.05.2011	O.SCHEIBE M24X1,5 SK6			3	0,000	
---	1315.334.074	ARTICULATION BOLT	1	Z0000407 5610	01.07.2011	01.07.2011				5	0,000	
300	0731.201.563	CYLINDRICAL PIN	3		00.00.0000					5	0,000	
320	1316.301.042	GASKET	1		00.00.0000				133-158-1320	5	0,000	
340	1315.301.118	INTERMPLATE	1		00.00.0000		ENTHALT.IN 1315 301 144(0)			5	0,000	
360	1316.301.042	GASKET	1		00.00.0000				133-158-1320	5	0,000	
420	---	SCREW PLUG	1	Z0001011 1513	01.01.2012	01.01.2012	35N.M*DICHTRING M18X1,5			3	0,000	
---	0636.100.791	SCREW PLUG	1	Z0001011 1521	15.11.2010	15.11.2010	M18X1,5			5	0,000	
---	0634.801.062	SEALING RING	1	Z0001011 1521	15.11.2010	15.11.2010	18X24			5	0,001	
450	---	PULSE SENSOR	1	Z0000428 7211	20.05.2010	20.05.2010	35N.M*FLAE.DICHTG *BAJONETT*L=90,0* SCHUTZKAPPE			3	0,000	

VKF Incidence factor

OTK Optional technical kit

ID Identification (output code)

SP Supplier plant



Pos.	Material number	Name	VKF	Amend. no.	Amend. start	Prod. no.	Material feature / tech. info.	OTK	External material no.	ID	Weight	SP
---	0501.210.859	PULSE SENSOR	1	Z0000428 7210	20.05.2010	20.05.2010				5	0,000	
---	0666.790.033	SEALCOMPOUND	1	Z0000428 7210	20.05.2010	20.05.2010				5	0,310	
---	0700.300.427	PROTECTING CAP	1	Z0000428 7210	20.05.2010	20.05.2010				5	0,005	
500	0736.300.123	HEXAGON BOLT	11		00.00.0000		M10X70 M10X70			5	0,000	
510	0736.300.123	HEXAGON BOLT	1		00.00.0000		M10X70 M10X70			5	0,000	
520	0736.300.123	HEXAGON BOLT	1		00.00.0000		M10X70 M10X70			5	0,000	
530	0736.300.123	HEXAGON BOLT	1		00.00.0000		M10X70 M10X70			5	0,000	
540	0736.300.122	HEXAGON BOLT	2	Z0000940 3110	31.12.2011	31.12.2011	M10X110 M10X110			5	0,000	
550	0736.300.134	HEXAGON BOLT	1	Z0001110 3210	30.06.2011	30.06.2011	M10X45 M10X45			5	0,000	
560	0736.300.123	HEXAGON BOLT	2		00.00.0000		M10X70 M10X70			5	0,000	
570	0736.300.123	HEXAGON BOLT	1		00.00.0000		M10X70 M10X70			5	0,000	
580	0736.300.123	HEXAGON BOLT	1		00.00.0000		M10X70 M10X70			5	0,000	
590	0736.300.134	HEXAGON BOLT	1	Z0001110 3210	30.06.2011	30.06.2011	M10X45 M10X45			5	0,000	
600	0736.300.123	HEXAGON BOLT	1		00.00.0000		M10X70 M10X70			5	0,000	
610	0736.300.123	HEXAGON BOLT	1		00.00.0000		M10X70 M10X70			5	0,000	

VKF Incidence factor

OTK Optional technical kit

ID Identification (output code)

SP Supplier plant

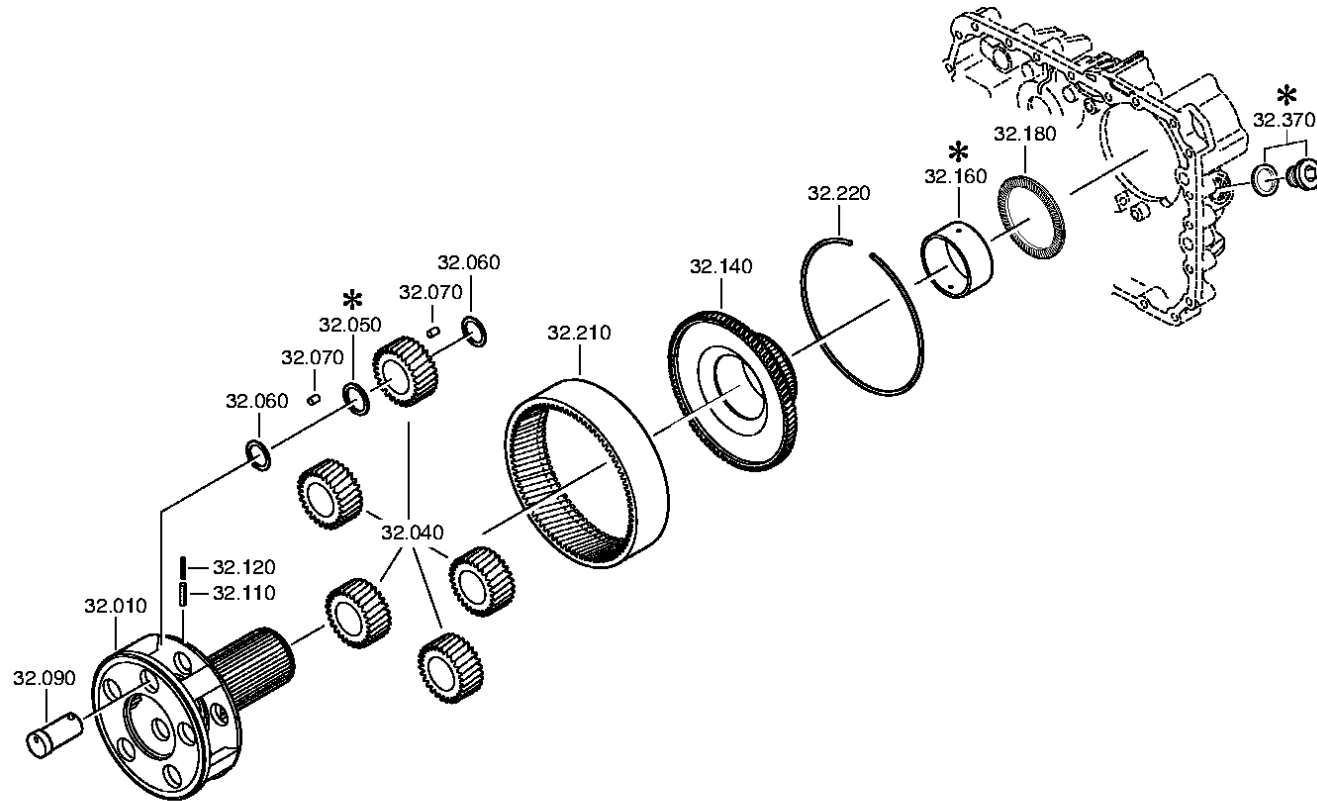

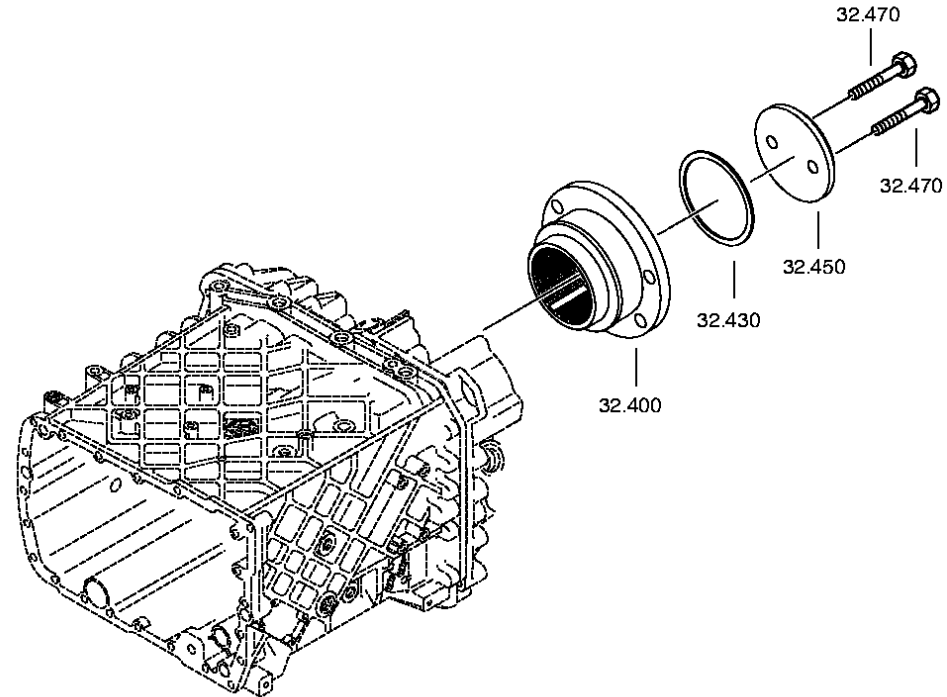



Pos.	Material number	Name	VKF	Amend. no.	Amend. start	Prod. no.	Material feature / tech. info.	OTK	External material no.	ID	Weight	SP
10	1315.232.017	PLANET CARRIER	1	C0100319 7C10	00.00.0000	00.00.0000	KPL.4,565*SV-GP*FL.PROF.90			3	0,000	
40	1315.232.010	PLANET GEAR SET	1		00.00.0000		KPL.			3	0,000	
60	0730.107.168	INTERMWASHER	15		00.00.0000		A=1,00 IN 0730 105 951(2)			5	0,000	
70	0750.119.116	ROLLER	140		00.00.0000		10,0X16,8		820-400-3060	3	0,000	
90	1315.332.053	PLANET SHAFT	5	C0100722 6B10	00.00.0000	00.00.0000	ENTHALT.IN 1316 332 037(2)			5	0,000	
110	0631.329.051	SLOTPIN	5		00.00.0000		5X26			5	0,002	
120	0631.329.167	SLOTPIN	5		00.00.0000		3X26			5	1	
140	1316.332.130	RING GEAR CARRIER	1	C0100730 5F10	00.00.0000	00.00.0000				5	0,000	
160	1316.333.014	INTERMRING	1		00.00.0000					5	0,000	
180	0735.298.169	AXIAL NEEDLE BEARING	1		00.00.0000		104,5X128,4X10,0 FA.INA		820-400-3080	5	0,000	
210	1315.332.041	RING GEAR	1		00.00.0000		IN 1316 332 055(1)			5	0,000	
220	0730.513.583	LOCKING WIRE	1		00.00.0000		A=3,20 IN 0730 505 052(2)			5	0,000	
400	1316.332.125	OUTPUT FLANGE	1		00.00.0000					5	0,000	
430	0634.313.805	O-RING	1		00.00.0000		82X4			5	0,000	
450	1312.332.028	WASHER	1		00.00.0000					5	0,000	
470	0636.011.777	HEXAGON BOLT	2	Z0000729 2012	01.01.2012	01.01.2012	M12X60			5	0,000	

VKF Incidence factor

OTK Optional technical kit

ID Identification (output code)

SP Supplier plant

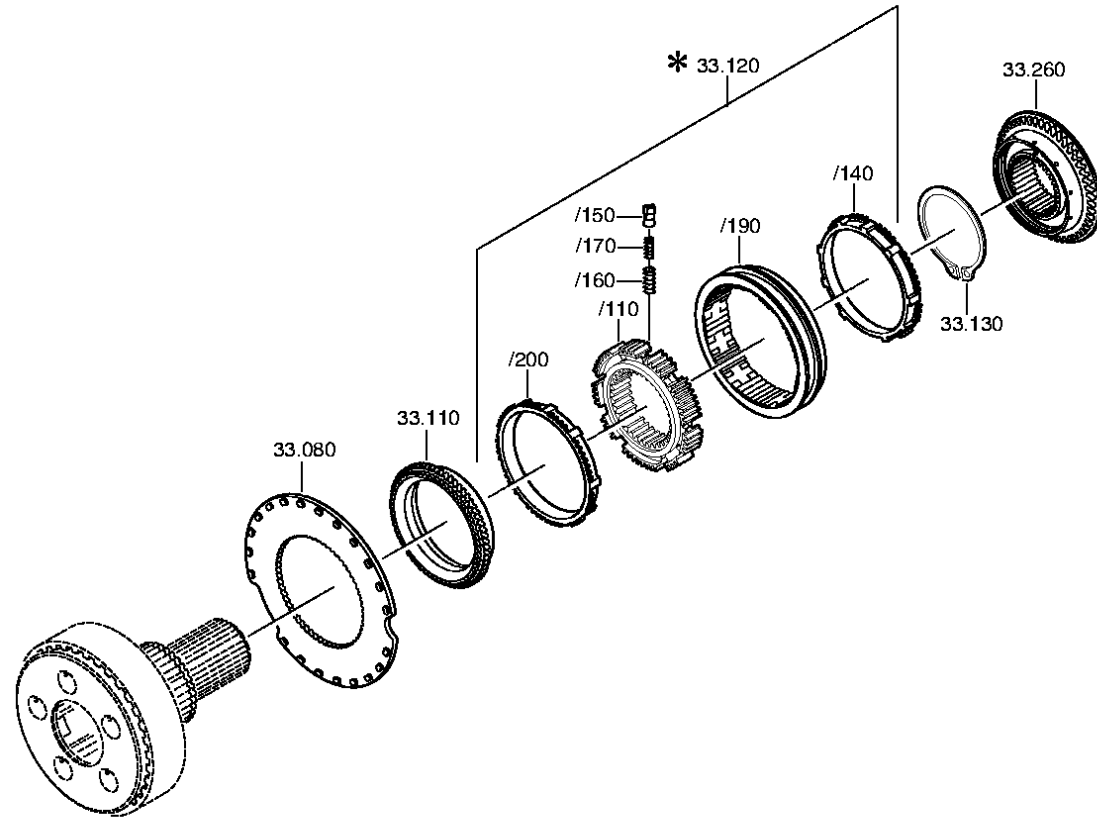

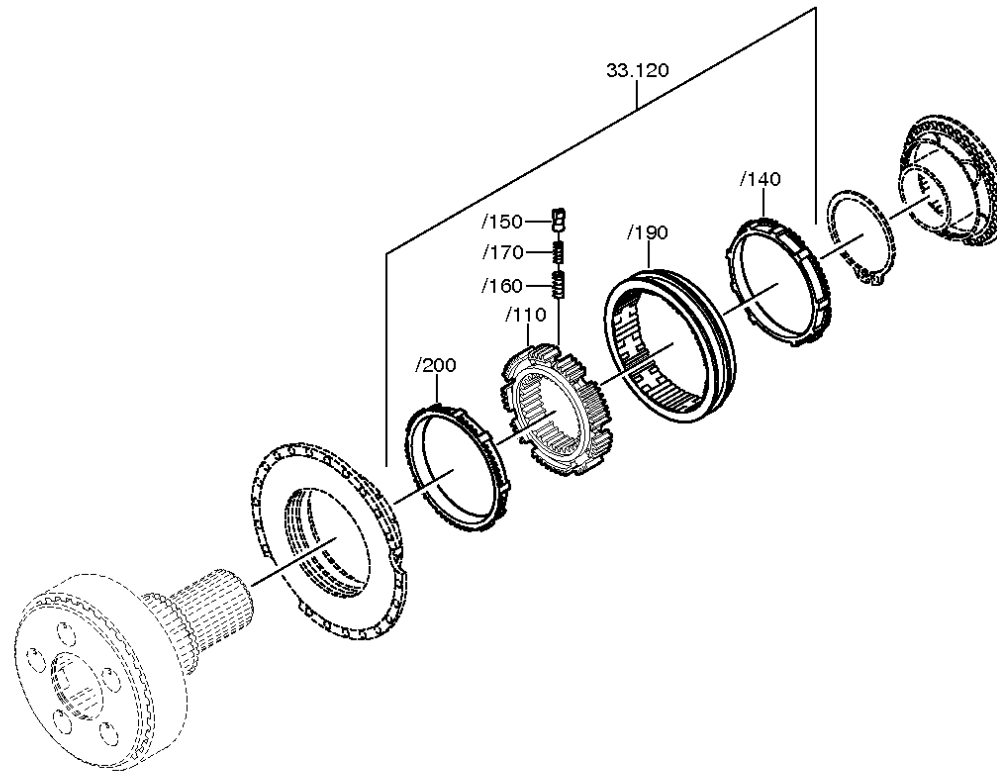



Pos.	Material number	Name	VKF	Amend. no.	Amend. start	Prod. no.	Material feature / tech. info.	OTK	External material no.	ID	Weight	SP
80	1296.333.046	CLUTCH DISC	1		00.00.0000		ENTHALT.IN 1296 333 051(1)			5	0,000	
110	1296.333.050	CLUTCH BODY	1	C0100262 7A10	00.00.0000	00.00.0000	ENTHALT.IN 1296.333.053(1)			5	0,000	
120	1316.233.022	SYNCHRONIZER	1		00.00.0000		KPL.PROFIL 80GV-GP 90SV-GP			3	0,000	
/110	1313.333.001	SYNCHROBODY	1		00.00.0000		ENTHALT.IN 1296 333 014(1)			5	0,000	
/140	1296.333.045	SYNCHRORING	1		00.00.0000					5	0,000	
/150	1240.304.278	PRESSURE PIECE	9		00.00.0000				1334510410	5	0,000	
/160	0732.040.385	COMPRSPRING	9		00.00.0000				0971040080	5	0,000	
/170	0732.040.386	COMPRSPRING	9		00.00.0000				097102000	5	0,000	
/190	1316.333.034	SLIDING SLEEVE	1	C0100731 7F10	00.00.0000	00.00.0000	ZF-B 165/74 GP			5	0,000	
/200	1296.333.045	SYNCHRORING	1		00.00.0000					5	0,000	
130	0630.501.175	RETAINING RING	1	Z0000694 3010	20.12.2010	20.12.2010	125X3,7			5	0,000	
260	1316.233.029	CLUTCH BODY	1	C0100730 5F10	00.00.0000	00.00.0000	KPL. ZF-B 165/74			3	0,000	

VKF Incidence factor

OTK Optional technical kit

ID Identification (output code)

SP Supplier plant

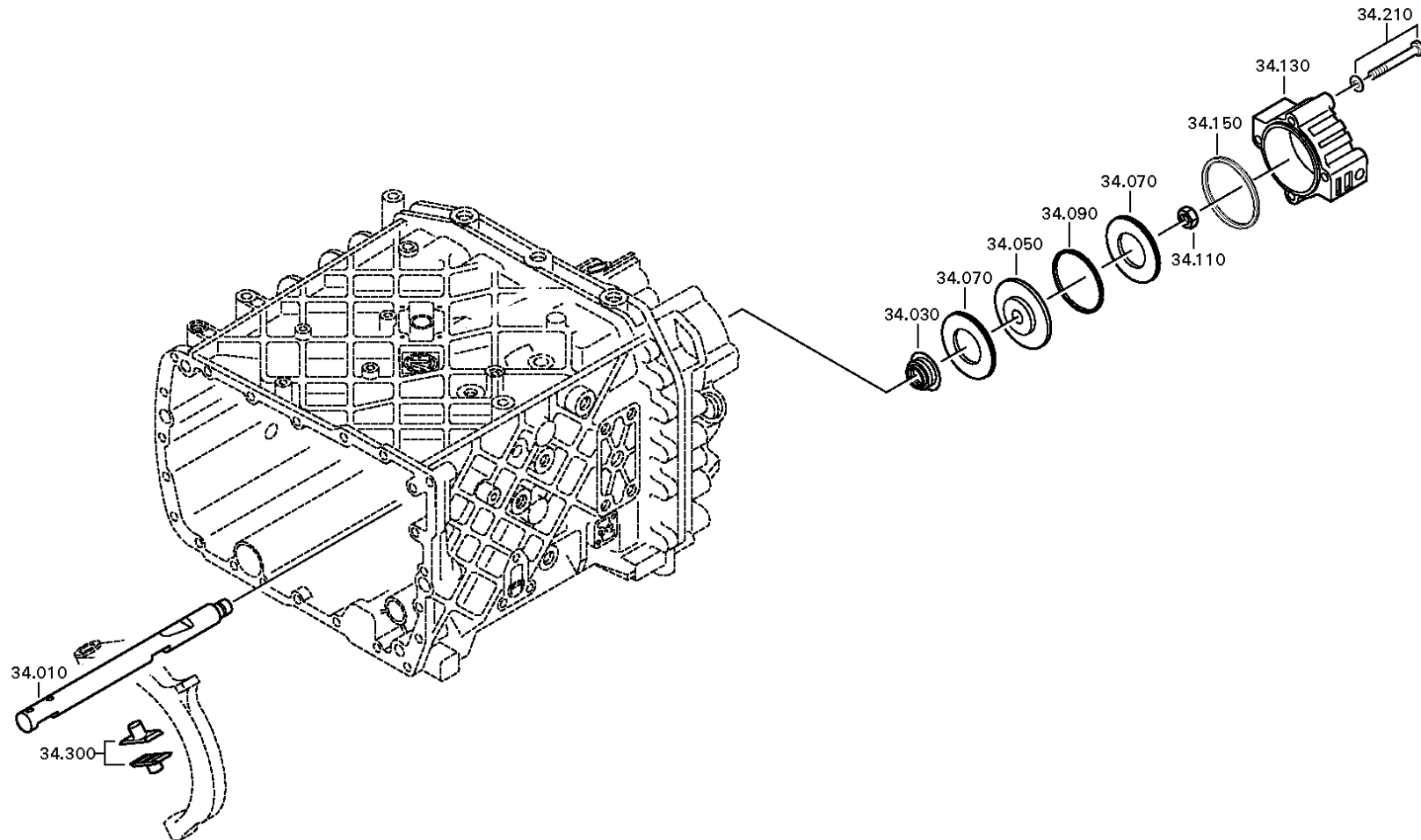

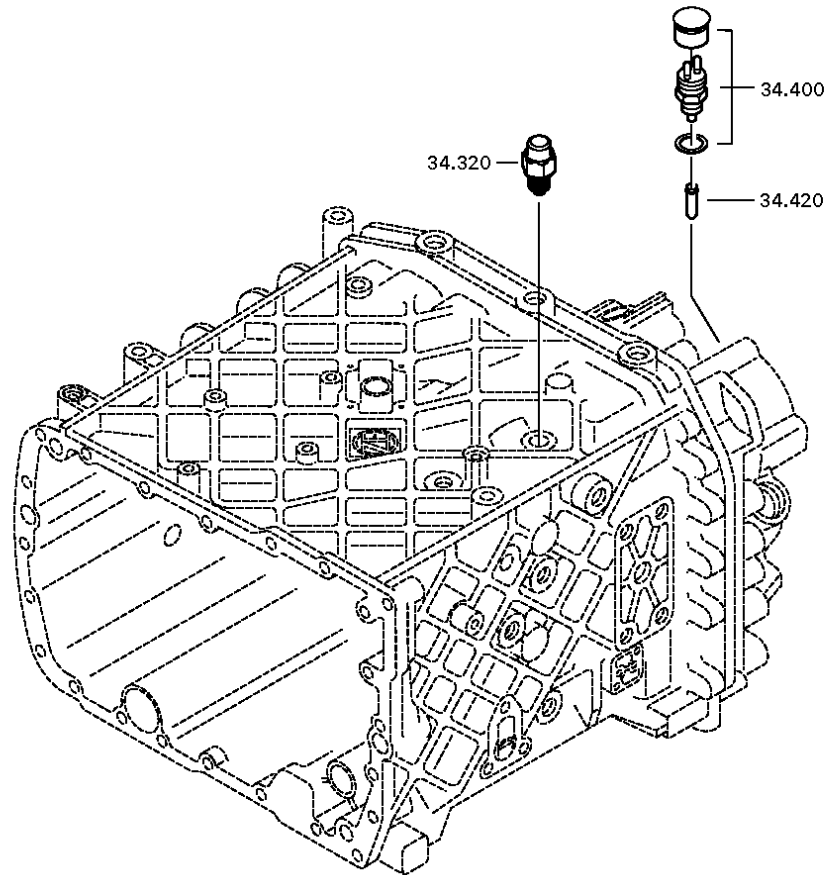



Pos.	Material number	Name	VKF	Amend. no.	Amend. start	Prod. no.	Material feature / tech. info.	OTK	External material no.	ID	Weight	SP
10	1315.334.071	GEAR SHIFT RAIL	1		00.00.0000					5	0,000	
30	0750.112.253	FLANGE PACKING	1		00.00.0000		25X40X15			3	0,000	
50	---	PISTON	1		00.00.0000		GP			3	0,000	
---	1315.334.034	PISTON	1		00.00.0000		ENTHALT.IN 1315 334 040(2)			5	0,000	
---	1315.334.063	PISTON	1		00.00.0000					5	0,000	
70	0734.307.294	SEALING RING	2		00.00.0000		49X91X7,4 FA.KACO			5	0,000	
90	0750.112.066	GUIDE RING	1		00.00.0000				5 5131 0	3	0,000	
110	0737.300.037	LOCKING NUT	1	Z0000892 9010	31.12.2011	31.12.2011	MS16X1,5			5	0,000	
130	1315.334.069	CYLINDER	1		00.00.0000					5	0,000	
150	0501.317.536	PROFILE SEALING RING	1		00.00.0000					5	0,000	
210	---	HEXAGON BOLT	4	Z0000734 9210	31.12.2011	31.12.2011	M10X90			3	0,000	
---	0636.015.688	HEXAGON BOLT	4	Z0000734 9212	11.10.2010	11.10.2010	M10X90			5	0,000	
---	0630.100.294	WASHER	4	Z0000715 8111	01.01.2012	01.01.2012				5	0,000	
300	1296.334.004	SLIDING PAD	2		00.00.0000				99532200	5	0,000	
320	---	DETENT PLUNGER	1		00.00.0000		145N*50N.M			3	0,000	
---	1324.207.035	DETENT PLUNGER	1		00.00.0000		KPL. *145 N			3	0,000	
---	0730.008.604	SEALING RING	1		00.00.0000					5	0,000	
400	---	SWITCH	1	Z0000428 7211	20.05.2010	20.05.2010	SCHL*45N.M*DICHTRING* BAJONETT*SCHUTZKAPPE			3	0,000	
---	0501.210.058	SWITCH	1		00.00.0000		KPL.		1864900531	5	0,000	
---	0634.801.062	SEALING RING	1		00.00.0000		18X24			5	0,001	
---	0700.300.427	PROTECTING CAP	1		00.00.0000					5	0,005	
420	1295.212.006	PIN	1		00.00.0000		KPL.			3	0,000	

VKF Incidence factor

OTK Optional technical kit

ID Identification (output code)

SP Supplier plant

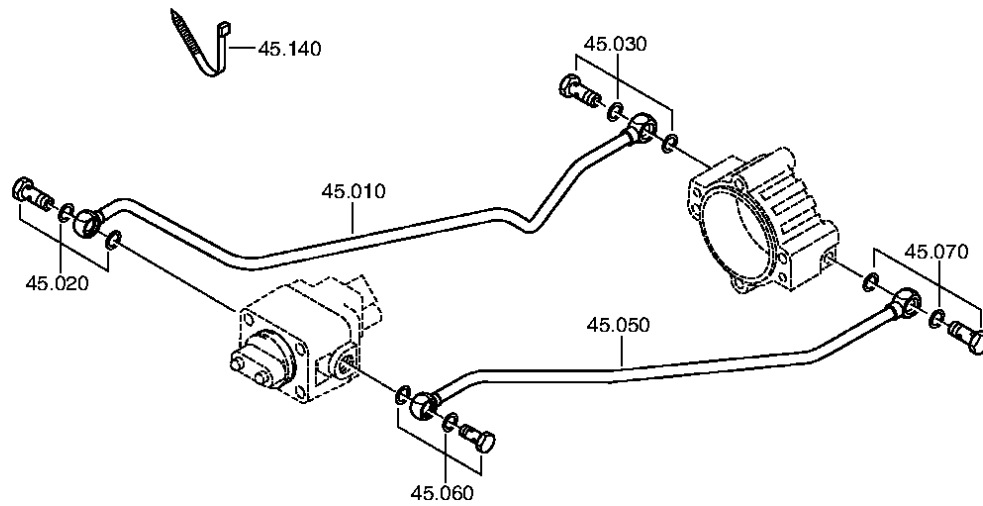



Pos.	Material number	Name	VKF	Amend. no.	Amend. start	Prod. no.	Material feature / tech. info.	OTK	External material no.	ID	Weight	SP
10	1315.245.016	PIPE	1	C0100383 3B10	00.00.0000	00.00.0000	KPL.GP RE*L=515MM*12X1,5			3	0,000	
20	---	UNION SCREW	1	Z0001027 4511	31.12.2011	31.12.2011	M14X1,5			3	0,000	
---	0737.300.061	UNION SCREW	1	Z0001027 4513	27.10.2010	27.10.2010	M14X1,5			5	0,000	
---	0634.801.217	SEALING RING	1	Z0001027 4513	27.10.2010	27.10.2010	14X20			5	0,000	
30	---	UNION SCREW	1	Z0001027 4511	31.12.2011	31.12.2011	M14X1,5			3	0,000	
---	0737.300.061	UNION SCREW	1	Z0001027 4513	27.10.2010	27.10.2010	M14X1,5			5	0,000	
---	0634.801.217	SEALING RING	1	Z0001027 4513	27.10.2010	27.10.2010	14X20			5	0,000	
50	1315.245.017	PIPE	1	C0100383 3B10	00.00.0000	00.00.0000	KPL.GP LI*L=532MM*12X1,5			3	0,000	
60	---	UNION SCREW	1	Z0001027 4511	31.12.2011	31.12.2011	M14X1,5			3	0,000	
---	0737.300.061	UNION SCREW	1	Z0001027 4513	27.10.2010	27.10.2010	M14X1,5			5	0,000	
---	0634.801.217	SEALING RING	1	Z0001027 4513	27.10.2010	27.10.2010	14X20			5	0,000	
70	---	UNION SCREW	1	Z0001027 4511	31.12.2011	31.12.2011	M14X1,5			3	0,000	
---	0737.300.061	UNION SCREW	1	Z0001027 4513	27.10.2010	27.10.2010	M14X1,5			5	0,000	
---	0634.801.217	SEALING RING	1	Z0001027 4513	27.10.2010	27.10.2010	14X20			5	0,000	
140	0659.160.081	CABLE CLIP	1	C0100665 4E10	00.00.0000	00.00.0000	4,7X210			5	0,000	

VKF Incidence factor

OTK Optional technical kit

ID Identification (output code)

SP Supplier plant

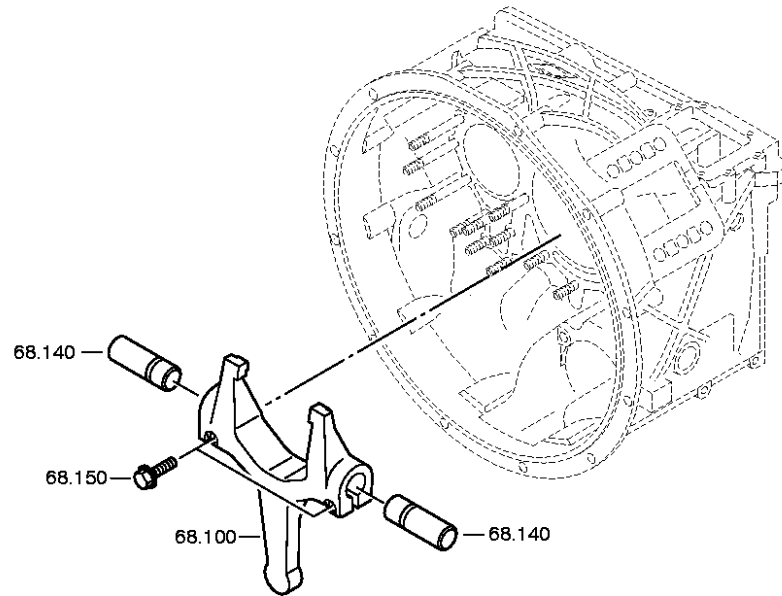

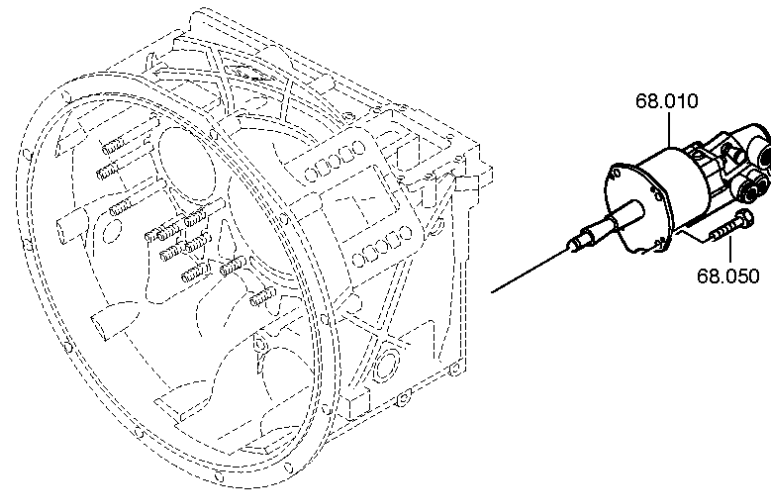



Pos.	Material number	Name	VKF	Amend. no.	Amend. start	Prod. no.	Material feature / tech. info.	OTK	External material no.	ID	Weight	SP
10	0501.008.720	CLUTCH CYLINDER	1	C0100433 1F10	00.00.0000	00.00.0000				5	0,000	
50	0636.016.412	HEXAGON BOLT	4		00.00.0000		M8X22			5	0,000	
100	1315.268.031	RELEASE FORK	1	Z0000539 7611	20.04.2011	20.04.2011	KPL.AUSR-WELLE*SW=78			3	0,000	
/120	0501.315.159	BALL CUP	1		00.00.0000		KS12-18-12			5	0,000	
140	---	SHAFT	2	Z0000466 7010	12.05.2011	12.05.2011				3	0,000	
---	1315.368.060	SHAFT	2		00.00.0000					5	0,000	
---	0671.190.050	GREASE	2		00.00.0000					5	0,000	
150	---	LOCKING SCREW	2		00.00.0000		DURLOK M10X45			3	0,000	
---	0736.031.059	LOCKING SCREW	2	C0100947 3D10	00.00.0000	00.00.0000	M10X45		530537A080980 REPL. FOR 0636031070	5	0,000	

VKF Incidence factor

OTK Optional technical kit

ID Identification (output code)

SP Supplier plant